

**COMPLEX
SOLUTIONS
MADE
SIMPLE.**



DSEPOWER[®]

DSE7510 MK1 Control Module

Document Number 057-088

Author : Anthony Manton



Deep Sea Electronics Plc
 Highfield House
 Hunmanby
 North Yorkshire
 YO14 0PH
 ENGLAND

Sales Tel: +44 (0) 1723 890099
 Sales Fax: +44 (0) 1723 893303

E-mail: sales@deepseapl.com
 Website: www.deepseapl.com

DSE Model 7510MK1 Autostart Control and Instrumentation System Operators Manual

© Deep Sea Electronics Plc

All rights reserved. No part of this publication may be reproduced in any material form (including photocopying or storing in any medium by electronic means or other) without the written permission of the copyright holder except in accordance with the provisions of the Copyright, Designs and Patents Act 1988.

Applications for the copyright holder’s written permission to reproduce any part of this publication should be addressed to Deep Sea Electronics Plc at the address above.

The DSE logo and the names DSEUltra, DSEControl, DSEPower, DSEExtra, DSEMarine and DSENet are UK registered trademarks of Deep Sea Electronics PLC.

Any reference to trademarked product names used within this publication is owned by their respective companies.

Deep Sea Electronics Plc reserves the right to change the contents of this document without prior notice.

Amendments since last publication

Amd. No.	Comments
1	Converted 5510 V8 manual to 7510 V10
2	Update to wiring diagrams (issue10.1)
3	Added Manual fuel pump and speed control (Issue 10.2)
4	Added current consumption figures, description of -002- hardware change (Issue 10.3), changes to overcurrent, earth fault and short circuit description layout.
5	Added AVR Trim Limit alarm (V11 firmware)

Clarification of notation used within this publication.



 NOTE:	Highlights an essential element of a procedure to ensure correctness.
 CAUTION!	Indicates a procedure or practice, which, if not strictly observed, could result in damage or destruction of equipment.
 WARNING!	Indicates a procedure or practice, which could result in injury to personnel or loss of life if not followed correctly.

TABLE OF CONTENTS

Section	Page
1 BIBLIOGRAPHY.....	6
2 INTRODUCTION.....	8
2.1 COMPATIBILITY.....	8
2.2 FEATURES.....	9
3 SPECIFICATIONS.....	10
3.1 PART NUMBERING	10
3.1.1 SHORT NAMES.....	10
3.1 POWER SUPPLY REQUIREMENTS	11
3.2 TERMINAL SPECIFICATION.....	11
3.3 GENERATOR VOLTAGE / FREQUENCY SENSING	11
3.4 INPUTS	11
3.4.1 DIGITAL INPUTS	11
3.4.2 CHARGE FAIL INPUT	12
3.4.3 MAGNETIC PICKUP	12
3.5 OUTPUTS	12
3.5.1 OUTPUTS A & B (FUEL AND START)	12
3.5.2 CONFIGURABLE OUTPUTS C & D (LOAD SWITCHING).....	12
3.5.3 CONFIGURABLE OUTPUTS E, F & G.....	12
3.6 COMMUNICATION PORTS	13
3.7 ACCUMULATED INSTRUMENTATION	13
3.8 SOUNDER	13
3.9 DIMENSIONS AND MOUNTING.....	14
3.9.1 FIXING CLIPS	15
3.9.2 CABLE TIE FIXING POINTS.....	16
3.9.3 SILICON SEALING GASKET	16
3.10 APPLICABLE STANDARDS.....	17
4 INSTALLATION.....	18
4.1 USER CONNECTIONS	18
4.2 TERMINAL DESCRIPTION	19
4.2.1 DC SUPPLY, FUEL AND START OUTPUTS, OUTPUTS E,F,G	19
4.2.2 ANALOGUE SENSOR	19
4.2.3 MAGNETIC PICKUP, CAN AND EXPANSION.....	21
4.2.4 LOAD SWITCHING AND GENERATOR VOLTAGE SENSING.....	22
4.2.5 BUS / MAINS VOLTAGE SENSING.....	22
4.2.6 GENERATOR CURRENT TRANSFORMERS	23
4.2.7 CONFIGURABLE DIGITAL INPUTS	24
4.2.8 PC CONFIGURATION INTERFACE CONNECTOR.....	24
4.2.9 EXPANSION INTERFACE CONNECTOR.....	24
4.2.10 RS485 CONNECTOR.....	25
4.2.11 RS232 CONNECTOR.....	25
4.2.12 ENGINE CONTROL UNIT INTERFACE.....	27
4.2.13 LED INDICATORS AND LOGO INSERT	28
5 OPERATION.....	29
5.1 CONTROL.....	29
5.1.1 DESCRIPTION OF CONTROLS.....	30
6 CONTROL PUSH-BUTTONS	31
6.1 AUTOMATIC MODE OF OPERATION.....	33
6.2 MANUAL OPERATION	36
6.2.1 MANUAL FUEL PUMP CONTROL.....	38

6.2.2	MANUAL SPEED CONTROL.....	38
7	PROTECTIONS.....	39
7.1	WARNINGS.....	40
7.2	ANALOGUE PRE-ALARMS.....	42
7.3	SHUTDOWNS.....	43
7.4	ELECTRICAL TRIPS.....	47
7.5	DELAYED OVERCURRENT SHUTDOWN / ELECTRICAL TRIP ALARM.....	48
7.5.1	IMMEDIATE WARNING.....	48
7.5.2	IDMT ALARM.....	48
7.6	EARTH FAULT AND SHORT CIRCUIT TRIPPING CURVES (TYPICAL).....	50
7.7	ROCOF / VECTOR SHIFT.....	50
7.8	TYPICAL LCD DISPLAY SCREENS.....	51
7.8.1	TYPICAL STATUS DISPLAY.....	51
7.8.2	TYPICAL INSTRUMENT DISPLAY.....	52
7.8.3	TYPICAL ALARM DISPLAY.....	52
7.8.4	TYPICAL EVENT DISPLAY.....	53
7.9	VIEWING THE INSTRUMENT AND EVENT LOG PAGES.....	54
7.9.1	SYNCHROSCOPE OPERATION.....	55
7.10	COMPLETE INSTRUMENTATION LIST.....	56
7.10.1	BASIC INSTRUMENTATION.....	56
7.10.2	ENHANCED ENGINE INSTRUMENTATION.....	56
7.11	THE FRONT PANEL CONFIGURATION EDITOR.....	57
7.11.1	ACCESSING THE FRONT PANEL CONFIGURATION EDITOR.....	57
7.11.2	EDITING A PARAMETER.....	57
7.11.3	ADJUSTABLE PARAMETERS.....	58
7.12	THE 'RUNNING' CONFIGURATION EDITOR.....	59
7.12.1	ADJUSTABLE PARAMETERS (RUNNING EDITOR).....	59
8	COMMISSIONING.....	60
8.1	BYPASSING ALARMS AT STARTUP.....	62
8.2	COMMISSIONING SCREENS.....	62
8.2.1	SCREEN 1.....	62
8.2.2	SCREEN 2.....	62
9	FAULT FINDING.....	63
10	TYPICAL WIRING DIAGRAMS.....	64
10.1	3 PHASE 4 WIRE SYSTEM WITH RESTRICTED EARTH FAULT.....	64
10.2	ALTERNATIVE TOPOLOGIES.....	65
10.2.1	3 PHASE, 4 WIRE WITHOUT EARTH FAULT PROTECTION.....	65
10.2.2	SINGLE PHASE WITH RESTRICTED EARTH FAULT.....	66
10.2.3	SINGLE PHASE WITHOUT EARTH FAULT.....	66
10.2.4	2 PHASE (L1 & L2) 3 WIRE WITH RESTRICTED EARTH FAULT.....	67
10.2.5	2 PHASE (L1 & L2) 3 WIRE WITHOUT EARTH FAULT.....	67
10.2.6	2 PHASE (L1 & L3) 3 WIRE WITH RESTRICTED EARTH FAULT.....	68
10.2.7	2 PHASE (L1 & L3) 3 WIRE WITHOUT EARTH FAULT MEASURING.....	68
10.2.8	3 PHASE 4 WIRE WITH UNRESTRICTED EARTH FAULT MEASURING.....	69
11	SENSOR WIRING RECOMMENDATIONS.....	70
11.1	USING EARTH RETURN (SINGLE WIRE) SENSORS.....	70
11.2	USING INSULATED RETURN (TWO WIRE) SENSORS.....	70
12	APPENDIX.....	71
12.1	ACCESSORIES.....	71
12.1.1	OUTPUT EXPANSION.....	71
	RELAY OUTPUT EXPANSION (157).....	71
	LED OUTPUT EXPANSION (548).....	71
12.1.2	INPUT EXPANSION (P130/P540/P541).....	71
12.2	COMMUNICATIONS OPTION.....	72

12.2.1	DESCRIPTION	72
12.2.2	CONTROLLER TO PC (DIRECT) CONNECTION.....	72
12.2.3	CONTROLLER TO ETHERNET CONNECTION.....	73
12.2.4	CONTROLLER TO MODEM CONNECTION.....	74
12.2.5	RS485 LINK TO CONTROLLER.....	75
	TYPICAL BUILDING MANAGEMENT SCHEME USING RS485 MONITORING.....	76
12.2.6	MODBUS	76
12.3	ENCLOSURE CLASSIFICATIONS	77
	IP CLASSIFICATIONS	77
	NEMA CLASSIFICATIONS	78
12.4	IEEE C37.2 STANDARD ELECTRICAL POWER SYSTEM DEVICE FUNCTION NUMBERS.....	79
12.5	SYNCHRONISING NOTES.....	81
12.5.1	CHECK SYNC.....	81
12.5.2	AUTO SYNC.....	81
12.5.3	LOAD CONTROL.....	81
12.5.4	TYPICAL LOAD SHARING SYSTEM.....	82
12.5.5	TYPICAL PEAK SHAVING SYSTEM	82

1 BIBLIOGRAPHY

This document refers to and is referred to by the following DSE publications which can be obtained from the DSE website www.deepseapl.com

1.1 INSTALLATION INSTRUCTIONS

Installation instructions are supplied with the product in the box and are intended as a 'quick start' guide only.

DSE PART	DESCRIPTION
051-157	DSE130 input expansion module installation instructions
053-040	DSE157 expansion relay board installation instructions
053-052	DSE7510 installation instructions
053-053	DSE7520 installation instructions
053-054	DSE7560 installation instructions
053-055	DSE850 installation instructions
053-062	DSE860/DSE865 installation instructions

1.2 TRAINING GUIDES

Training Guides are produced to give 'handout' sheets on specific areas of the module operation.

DSE PART	DESCRIPTION
056-001	Four Steps to Synchronising and Load Sharing
056-005	Using CTs with DSE products
056-006	Introduction to Comms
056-010	Overcurrent protection
056-011	MSC Link
056-013	Load Demand Scheme
056-022	Breaker Control
056-018	Negative Phase Sequence
056-019	Earth Fault Protection
056-020	Loss of Excitation
056-021	Mains Decoupling
056-022	Breaker Control
056-024	GSM Modem
056-026	kW and kVAr
056-029	Smoke Limiting
056-030	Module PIN codes
056-031	5510 to 7510 conversion wiring list

1.3 MANUALS

DSE PART	DESCRIPTION
057-004	Electronic Engines and DSE wiring manual
057-046	DSE Guide to Synchronising and Load Sharing Part 2 – Governor and AVR Interfacing
056-047	Load Share Design and Commissioning
057-078	DSE7500 Series configuration software manual
057-089	DSE7520 operators manual
057-090	DSE7560 operators manual
057-098	Link7000 software manual

1.4 OTHER PUBLICATIONS

Additionally this document refers to the following third party publications

REFERENCE	DESCRIPTION
ISBN 1-55937-879-4	IEEE Std C37.2-1996 IEEE Standard Electrical Power System Device Function Numbers and Contact Designations. Institute of Electrical and Electronics Engineers Inc
ISBN 0-7506-1147-2	Diesel generator handbook. L.L.J.Mahon
ISBN 0-9625949-3-8	On-Site Power Generation. EGSA Education Committee.

2 INTRODUCTION

This document details the installation and operation requirements of the DSE7500 Series modules, part of the DSEPower® range of products.

The manual forms part of the product and should be kept for the entire life of the product. If the product is passed or supplied to another party, ensure that this document is passed to them for reference purposes.

This is not a *controlled document*. You will not be automatically informed of updates. Any future updates of this document will be included on the DSE website at www.deepseapl.com

2.1 COMPATIBILITY

The DSE7510 Mk1 controller is an update to the popular DSE5510. It maintains all the functions and flexibility of the DSE5510 while being packaged in DSE7000 series styling bringing with it the advantages of the DSE7000 series terminal compatibility easing system upgrades. The DSE7510 Mk1 controller is compatible with DSE5510 and DS5560 controllers when used in a multiple controller system, connected by the MSC (Multi-Set Communications) Link.

The DSE7510MK1 is also 100% compatible with modbus RTU applications written for the DSE5510 (including the DSE850 multiset comms package).

2.2 FEATURES

The **DSE 7510MK1** Module allows the OEM to meet demand for increased capability within the industry. It allows the user to start and stop the generator and if required, transfer the load to the generator either manually or automatically. The user also has the facility to view the system operating parameters via the LCD display.

Utilising the inbuilt synchronising, volts matching and paralleling functions, the controller is able to parallel with the mains supply for simple peak lopping (fixed generator output). Alternatively, the 7510MK1 can be used to parallel with other DSE 7510MK1 load sharing controllers. Up to 16 sets can be connected in paralleling and load share as a standalone (prime power) system. Additionally they can parallel with the mains supply (when used in conjunction with DSE 7560MK1).

The **DSE 7510MK1** module also monitors the engine, indicating the operational status and fault conditions, automatically shutting down the engine. Exact failure mode information is indicated by the LCD display on the front panel.

The powerful Microprocessor contained within the module allows for many features to be incorporated as standard;

- *Full Multilingual LCD display (including non-western character fonts).*
- *True R.M.S. voltage monitoring.*
- *Power measurement.*
- *Communications capability (RS485 or RS232 including GSM/SMS functions)*
- *Check Sync capability*
- *Automatic Sync capability*
- *Load share / control capability*
- *Fully configurable inputs for use as alarms or a range of different functions also available on P130 expansion inputs (optional)*
- *Extensive range of output functions using built in relay outputs or relay expansion available.*
- *Instrumentation and diagnostics from electronic engines when connected to an engine ECU.*

Selective operational sequences, timers and alarm trips can be altered by the customer via a PC using the 75xx For Windows™ software and 810 interface or via the integral front panel configuration editor.

Access to critical operational sequences and timers for use by qualified engineers, can be protected by a security code. Module access can also be protected by PIN code. Selected parameters can be changed from the module's front panel.

The module is housed in a robust plastic case suitable for panel mounting. Connections to the module are via locking plug and sockets.

3 SPECIFICATIONS

3.1 PART NUMBERING

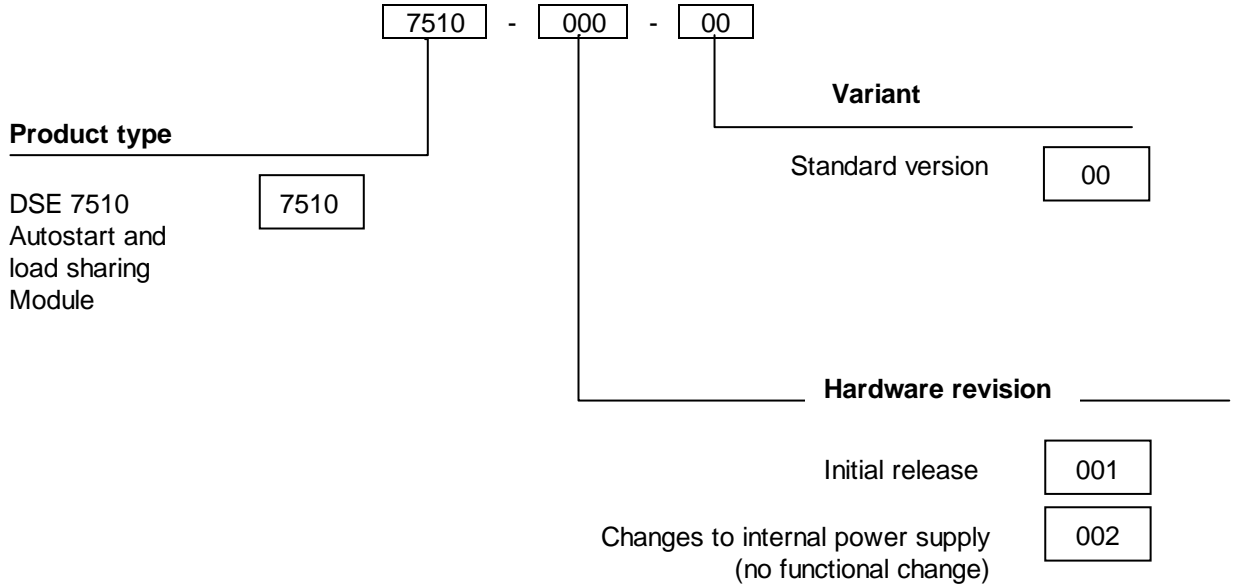

3.1.1 SHORT NAMES

Short name	Description
DSE7000	All modules in the DSE7000 Series
DSE7500	All modules in the DSE7500 sync/load share range
DSE7510	DSE7510 autostart module

3.2 POWER SUPPLY REQUIREMENTS

Minimum supply voltage	8V continuous
Cranking dropouts	Able to survive 0V for 50mS providing the supply was at least 10V before the dropout and recovers to 5V afterwards.
Maximum supply voltage	35V continuous (60V protection)
Reverse polarity protection	-35V continuous
Maximum operating current	260mA at 24V 510mA at 12V
Typical standby current	220mA at 24V 440mA at 12V

Plant supply instrumentation display

Range	0V-60V DC (note Maximum continuous operating voltage of 35V DC)
Resolution	0.1V
Accuracy	1% full scale

3.3 TERMINAL SPECIFICATION

Connection type	Screw terminal, rising clamp, no internal spring
Min cable size	0.5mm ² (AWG 24)
Max cable size	2.5mm ² (AWG 10)

3.4 GENERATOR VOLTAGE / FREQUENCY SENSING

Measurement type	True RMS conversion
Sample Rate	5KHz or better
Harmonics	Up to 10 th or better
Input Impedance	300K Ω ph-N
Phase to Neutral	15V to 333V AC (max)
Phase to Phase	25V to 576V AC (max)
Common mode offset from Earth	100V AC (max)
Resolution	1V AC phase to neutral 2V AC phase to phase
Accuracy	\pm 1% of full scale phase to neutral \pm 2% of full scale phase to phase
Minimum frequency	3.5Hz
Maximum frequency	75.0Hz
Frequency resolution	0.1Hz
Frequency accuracy	\pm 0.2Hz

3.5 INPUTS

3.5.1 DIGITAL INPUTS

Number	9
Arrangement	Contact between terminal and ground
Low level threshold	40% of DC supply voltage
High level threshold	60% of DC supply voltage
Maximum input voltage	DC supply voltage positive terminal
Minimum input voltage	DC supply voltage negative terminal
Contact wetting current	2.5mA @12V typical 5mA @ 24V typical
Open circuit voltage	Plant supply

3.5.2 CHARGE FAIL INPUT

Minimum voltage	0V
Maximum voltage	35V (plant supply)
Resolution	0.2V
Accuracy	± 1% of max measured voltage
Excitation	Active circuit constant power output
Output Power	2.5W Nominal @12V and 24V
Current at 12V	210mA
Current at 24V	105mA

3.5.3 MAGNETIC PICKUP

Type	Single ended input, capacitive coupled
Minimum voltage	0.5V RMS
Max common mode voltage	±2V
Maximum voltage	Clamped to ±70V by transient suppressers, dissipation not to exceed 1W.
Maximum frequency	10,000Hz
Resolution	6.25 RPM
Accuracy	±25 RPM
Flywheel teeth	10 to 500

3.6 OUTPUTS

3.6.1 OUTPUTS A & B (FUEL AND START)

Type	Fuel (A) and Start (B) outputs. Supplied from DC supply terminal 2.
Rating	3A @ 35V
Protection	Protected against over current & over temperature. Built in load dump feature.

3.6.2 CONFIGURABLE OUTPUTS C & D (LOAD SWITCHING)

Type	Fully configurable volts free relays. Output C – Normally Closed, Output D – Normally Open
Rating	8A @ 230V AC
Protection	Protected against over current & over temperature. Built in load dump feature.

3.6.3 CONFIGURABLE OUTPUTS E, F & G

Type	Fully configurable, supplied from DC supply terminal 2.
Rating	3A @ 35V
Protection	Protected against over current & over temperature. Built in load dump feature.

3.7 COMMUNICATION PORTS

810 port	For connection to the DSE810 interface only
Expansion port	For connection to DSE130, DSE157, DSE545, DSE548 expansion modules only
DSENet	DSE7510 Mk1 controller does not have DSENet expansion capability
CAN Port	Engine CAN Port Standard implementation of 'Slow mode', up to 250K bits/s Non Isolated. Internal Termination provided (120Ω)
Serial port	While both RS232 and RS485 are fitted to the module as standard, only one port can be used at a time (software selectable using configuration software) Additionally, if the 810 port is 'active' the RS232 / RS485 port is disabled.
RS232 Port	Non – Isolated port Max Baud rate 115K baud subject to S/W TX, RX, RTS, CTS, DSR, DTR, DCD Male 9 way D type connector Max distance 15m (50 feet)
RS485 Serial	Isolated Data connection 2 wire + common Half Duplex Data direction control for Transmit (by s/w protocol) Max Baud Rate 19200 External termination required (120R) Max common mode offset 70V (on board protection transorb) Max distance 1.2km (¾ mile)

3.8 ACCUMULATED INSTRUMENTATION

 **NOTE : When an accumulated instrumentation value exceeds the maximum number as listed below, it will reset and begin counting from zero again.**

Engine hours run	Maximum 99999 hrs 59 minutes (approximately 11yrs 4months)
Number of starts	1,000,000 (1 million)

3.9 SOUNDER

DSE7000 Series features an internal sounder to draw attention to warning, shutdown and electrical trip alarms.

Sounder level	84db @ 1m
---------------	-----------

3.10 DIMENSIONS AND MOUNTING

DIMENSIONS

240.0mm x 181.1mm x 41.7mm (9.4" x 7.1" x 1.6")

PANEL CUTOUT

220mm x 160mm (8.7" x 6.3")

WEIGHT

0.7kg (1.4lb)

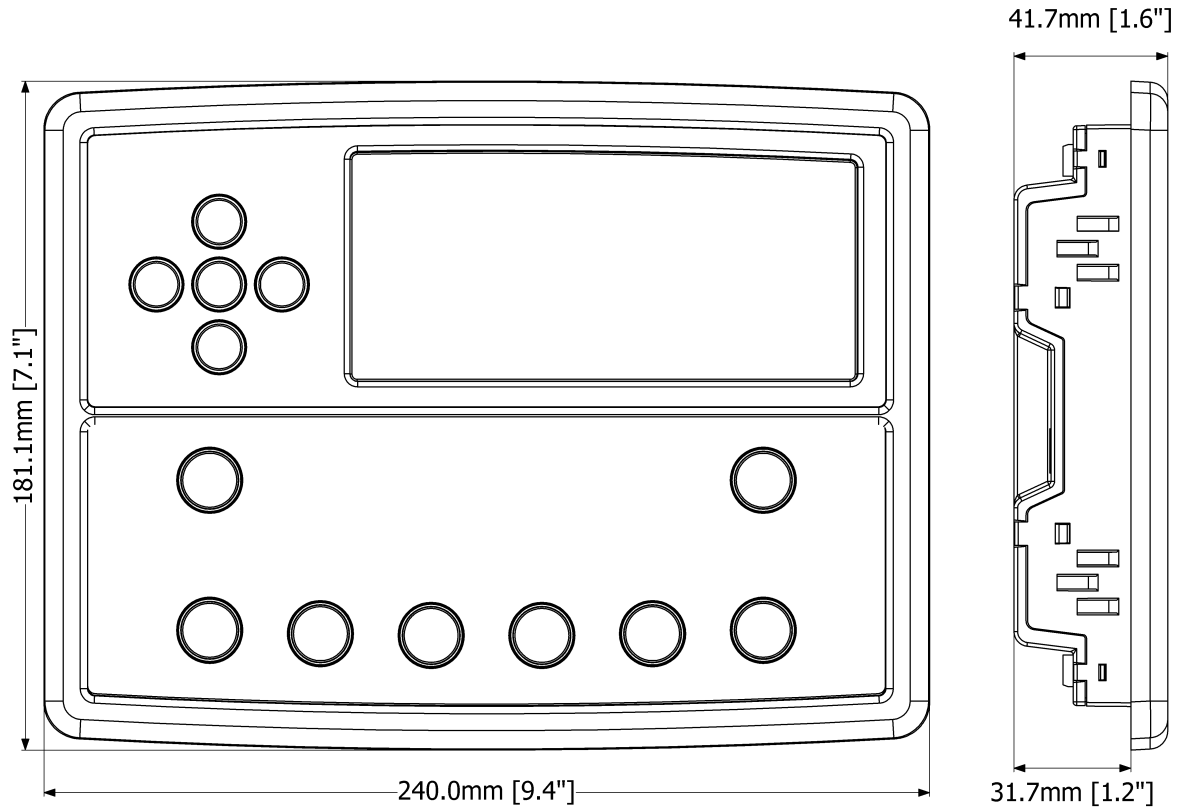

3.10.1 FIXING CLIPS

The module is held into the panel fascia using the supplied fixing clips.

- Withdraw the fixing clip screw (turn anticlockwise) until only the pointed end is protruding from the clip.
- Insert the three 'prongs' of the fixing clip into the slots in the side of the 7000 series module case.
- Pull the fixing clip backwards (towards the back of the module) ensuring all three prongs of the clip are inside their allotted slots.
- Turn the fixing clip screws clockwise until they make contact with the panel fascia.
- Turn the screws a little more to secure the module into the panel fascia. Care should be taken not to over tighten the fixing clip screws.

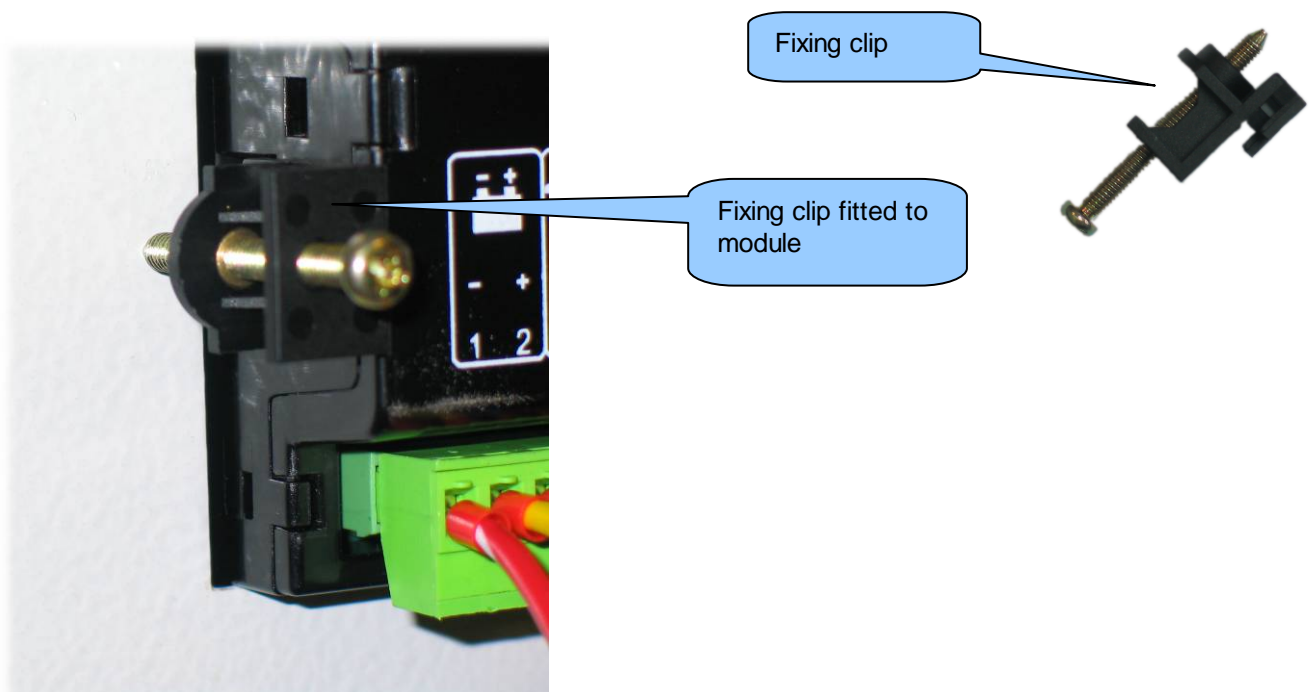

NOTE:- In conditions of excessive vibration, mount the module on suitable anti-vibration mountings.

3.10.2 CABLE TIE FIXING POINTS

Integral cable tie fixing points are included on the rear of the module's case to aid wiring. This additionally provides strain relief to the cable loom by removing the weight of the loom from the screw connectors, thus reducing the chance of future connection failures. Care should be taken not to over tighten the cable tie (for instance with cable tie tools) to prevent the risk of damage to the module case.



Cable tie fixing point

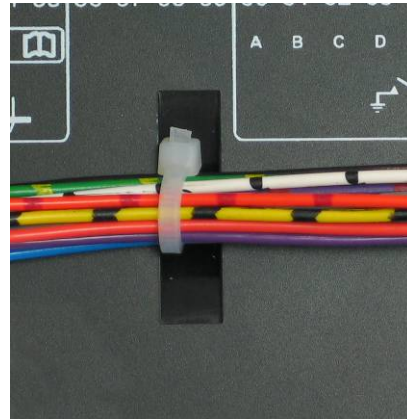

With cable and tie in place

3.10.3 SILICON SEALING GASKET

The supplied silicon gasket provides improved sealing between the 7000 series module and the panel fascia. The gasket is fitted to the module before installation into the panel fascia. Take care to ensure the gasket is correctly fitted to the module to maintain the integrity of the seal.

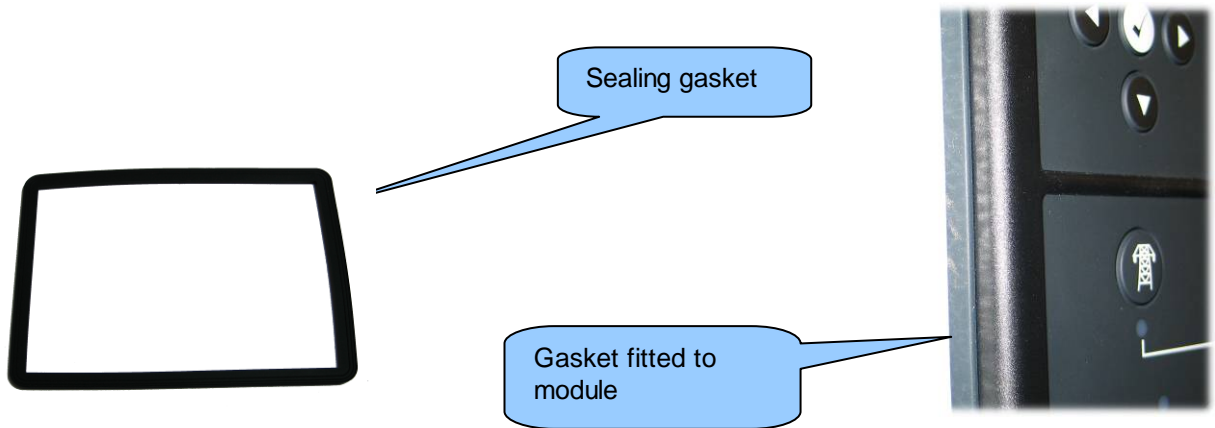

3.11 APPLICABLE STANDARDS

BS 4884-1	This document conforms to BS4884-1 1992 Specification for presentation of essential information.
BS 4884-2	This document conforms to BS4884-2 1993 Guide to content
BS 4884-3	This document conforms to BS4884-3 1993 Guide to presentation
BS EN 60068-2-1 (Minimum temperature)	-30°C (-22°F)
BS EN 60068-2-2 (Maximum temperature)	+70°C (158°F)
BS EN 60950	Safety of information technology equipment, including electrical business equipment
BS EN 61000-6-2	EMC Generic Immunity Standard (Industrial)
BS EN 61000-6-4	EMC Generic Emission Standard (Industrial)
BS EN 60529 (Degrees of protection provided by enclosures)	IP65 (front of module when installed into the control panel with the supplied sealing gasket) IP42 (front of module when installed into the control panel WITHOUT being sealed to the panel)
UL508 NEMA rating (Approximate)	12 (Front of module when installed into the control panel with the supplied sealing gasket). 2 (Front of module when installed into the control panel WITHOUT being sealed to the panel)
IEEE C37.2 (Standard Electrical Power System Device Function Numbers and Contact Designations)	<p>Under the scope of IEEE 37.2, <i>function numbers can also be used to represent functions in microprocessor devices and software programs.</i></p> <p>The 7000 series controller is device number 11L-7000 (Multifunction device protecting Line (generator) – 7000 series module).</p> <p>As the module is configurable by the generator OEM, the functions covered by the module will vary. Under the module's factory configuration, the device numbers included within the module are :</p> <ul style="list-style-type: none"> 2 – Time delay starting or closing relay 6 – Starting circuit breaker 27AC – AC undervoltage relay 27DC – DC undervoltage relay 30 – annunciator relay 42 – Running circuit breaker 50 – instantaneous overcurrent relay 51 – ac time overcurrent relay 52 – ac circuit breaker 53DC – exciter or dc generator relay 54 – turning gear engaging device 59AC – AC overvoltage relay 59DC – DC overvoltage relay 62 – time delay stopping or opening relay 63 – pressure switch 74– alarm relay 81 – frequency relay 86 – lockout relay

In line with our policy of continual development, Deep Sea Electronics, reserve the right to change specification without notice.

4 INSTALLATION

The DSE7000 Series module is designed to be mounted on the panel fascia. For dimension and mounting details, see the section entitled *Specification, Dimension and mounting* elsewhere in this document.

4.1 USER CONNECTIONS



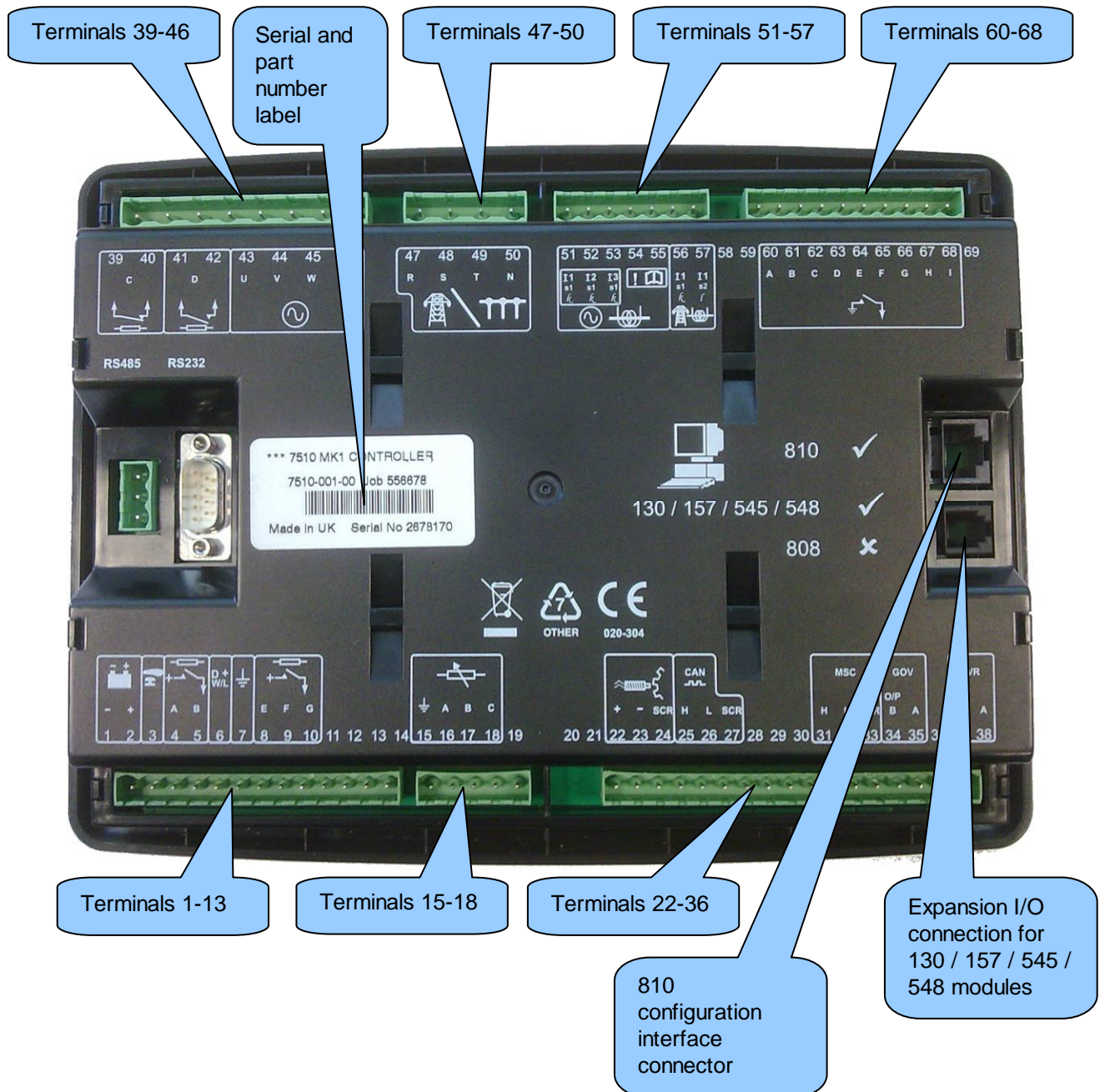

To aid user connection, icons are used on the rear of the module to help identify terminal functions. An example of this is shown below.

NOTE : Availability of some terminals depends upon module version. Full details are given in the section entitled *Terminal Description* elsewhere in this manual.



4.2 TERMINAL DESCRIPTION

4.2.1 DC SUPPLY, FUEL AND START OUTPUTS, OUTPUTS E,F,G

	PIN No	DESCRIPTION	CABLE SIZE	NOTES
	1	DC Plant Supply Input (Negative)	2.5mm ² AWG 13	
	2	DC Plant Supply Input (Positive)	2.5 mm ² AWG 13	(Recommended Maximum Fuse 15A anti-surge) Supplies the module (2A anti-surge requirement) and Output relays E,F,G & H
	3	Emergency Stop Input	2.5mm ² AWG 13	Plant Supply Positive. Also supplies outputs 1 & 2. (Recommended Maximum Fuse 20A)
	4	Output relay A (FUEL)	2.5mm ² AWG 13	Plant Supply Positive from terminal 3. 15 Amp rated. Fixed as FUEL relay if electronic engine is not configured.
	5	Output relay B (START)	2.5mm ² AWG 13	Plant Supply Positive from terminal 3. 15 Amp rated. Fixed as START relay if electronic engine is not configured.
D + W/L	6	Charge fail / excite	2.5mm ² AWG 13	Do not connect to ground (battery negative). If charge alternator is not fitted, leave this terminal disconnected.
	7	Functional Earth	2.5mm ² AWG 13	Connect to a good clean earth point.
	8	Output relay E	1.0mm ² AWG 18	Plant Supply Positive from terminal 2. 3 Amp rated.
	9	Output relay F	1.0mm ² AWG 18	Plant Supply Positive from terminal 2. 3 Amp rated.
	10	Output relay G	1.0mm ² AWG 18	Plant Supply Positive. from terminal 2. 3 Amp rated.

 **NOTE:-** Terminals 11 to 14 are not fitted to the DSE7510 MK1 controller.

 **NOTE:-** When the module is configured for operation with an electronic engine, FUEL and START output requirements may be different. Refer to *Electronic Engines and DSE Wiring* for further information. Part No. 057-004.



4.2.2 ANALOGUE SENSOR

	PIN No	DESCRIPTION	CABLE SIZE	NOTES
	15	Sensor Common Return	0.5mm ² AWG 20	Return feed for sensors*
	16	Oil Pressure Input	0.5mm ² AWG 20	Connect to Oil pressure sensor
	17	Coolant Temperature Input	0.5mm ² AWG 20	Connect to Coolant Temperature sensor
	18	Fuel Level input	0.5mm ² AWG 20	Connect to Fuel Level sensor
	19	Flexible sensor (not available on 7200 series controller)	0.5mm ² AWG 20	Connect to additional sensor (user configurable)

 **NOTE:-** Terminals 19 to 21 are not fitted to the DSE7510 MK1 controller.

 **NOTE*:-** If using single terminal sensors refer to the Appendix section entitled “Sensor wiring recommendations” elsewhere in this manual.

4.2.3 MAGNETIC PICKUP, CAN AND EXPANSION

	PIN No	DESCRIPTION	CABLE SIZE	NOTES
	22	Magnetic pickup Positive	0.5mm ² AWG 20	Connect to Magnetic Pickup device
	23	Magnetic pickup Negative	0.5mm ² AWG 20	Connect to Magnetic Pickup device
	24	Magnetic pickup screen	Shield	Connect to ground at one end only
	25	CAN port H	0.5mm ² AWG 20	Use only 120Ω CAN approved cable
	26	CAN port L	0.5mm ² AWG 20	Use only 120Ω CAN approved cable
	27	CAN port Common	0.5mm ² AWG 20	Use only 120Ω CAN approved cable



 **NOTE:-** Terminals 28 to 30 are not fitted to the DSE7510 MK1 controller

 **NOTE:-** Screened cable must be used for connecting the Magnetic Pickup, ensuring that the screen is earthed at one end ONLY.

 **NOTE:-** Screened 120Ω impedance cable specified for use with CAN must be used for the CAN link and the Multiset comms link.
DSE stock and supply Belden cable 9841 which is a high quality 120Ω impedance cable suitable for CAN use (DSE part number 016-030)

 **NOTE:-** When the module is configured for CAN operation, terminals 22, 23 & 24 should be left unconnected. Engine speed is transmitted to the 7000 series controller on the CAN link.
Refer to *Electronic Engines and DSE Wiring* for further information. Part No. 057-004.

4.2.4 LOAD SWITCHING AND GENERATOR VOLTAGE SENSING

	PIN No	DESCRIPTION	CABLE SIZE	NOTES
	39	Output relay C	1.0mm AWG 18	Normally configured to control mains contactor coil (Recommend 10A fuse)
	40	Output relay C	1.0mm AWG 18	Normally configured to control mains contactor coil
	41	Output relay D	1.0mm AWG 18	Normally configured to control generator contactor coil (Recommend 10A fuse)
	42	Output relay D	1.0mm AWG 18	Normally configured to control generator contactor coil
	43	Generator L1 (U) voltage monitoring	1.0mm ² AWG 18	Connect to generator L1 (U) output (AC) (Recommend 2A fuse)
	44	Generator L2 (V) voltage monitoring input	1.0mm ² AWG 18	Connect to generator L2 (V) output (AC) (Recommend 2A fuse)
	45	Generator L3 (W) voltage monitoring input	1.0mm ² AWG 18	Connect to generator L3 (W) output (AC) (Recommend 2A fuse)
	46	Generator Neutral (N) input	1.0mm ² AWG 18	Connect to generator Neutral terminal (AC)

 **NOTE:-** The above table describes connections to a three phase, four wire alternator. For alternative wiring topologies, please see the **ALTERNATIVE AC TOPOLOGIES** section of this manual.

4.2.5 BUS / MAINS VOLTAGE SENSING

	PIN No	DESCRIPTION	CABLE SIZE	NOTES
	47	Bus/Mains L1 (R) voltage monitoring	1.0mm AWG 18	Connect to Mains L1 (R) incoming supply (AC) (Recommend 2A fuse)
	48	Bus/Mains L2 (S) voltage monitoring	1.0mm AWG 18	Connect to Mains L1 (S) incoming supply (AC) (Recommend 2A fuse)
	49	Bus/Mains L3 (T) voltage monitoring	1.0mm AWG 18	Connect to Mains L1 (T) incoming supply (AC) (Recommend 2A fuse)
	50	Bus/ Mains Neutral (N) input	1.0mm AWG 18	Connect to Mains N incoming supply (AC)

 **NOTE:-** These terminals are for connection to the common generator bus in a multiset application or for connection to the mains supply in a base load application.

4.2.6 GENERATOR CURRENT TRANSFORMERS



WARNING!:- Do not disconnect this plug when the CTs are carrying current. Disconnection will open circuit the secondary of the C.T.'s and dangerous voltages may then develop. Always ensure the CTs are not carrying current and the CTs are short circuit connected before making or breaking connections to the module.

NOTE:- The DSE7510 MK1 module has a burden of 0.5VA on the CT. Ensure the CT is rated for the burden of the DSE7510 MK1 controller, the cable length being used and any other equipment sharing the CT. If in doubt, consult your CT supplier.

	PIN No	DESCRIPTION	CABLE SIZE	NOTES
	51	CT Secondary for Gen L1	2.5mm ² AWG 13	Connect to s1 secondary of L1 monitoring CT
	52	CT Secondary for Gen L2	2.5mm ² AWG 13	Connect to s1 secondary of L2 monitoring CT
	53	CT Secondary for Gen L3	2.5mm ² AWG 13	Connect to s1 secondary of L3 monitoring CT

Connection to terminals 54 & 55

The function of terminals 54 and 55 change position depending upon wiring topology as follows :

Topology	Pin No	Description	CABLE SIZE
	54	DO NOT CONNECT	
	55	Common for CTs connected to L1,L2,L3	2.5mm ² AWG 13
	54	Common for CTs connected to L1,L2,L3,N	2.5mm ² AWG 13
	55	Connect to CT on the neutral conductor	2.5mm ² AWG 13
	54	Connect to CT on the neutral to earth link	
	55	Common for CTs connected to L1,L2,L3	2.5mm ² AWG 13

NOTE:- Terminals 56 to 59 are not fitted to the DSE7510 MK1 controller.

NOTE:- Take care to ensure correct polarity of the CT primary as shown below. If in doubt, check with the CT supplier.

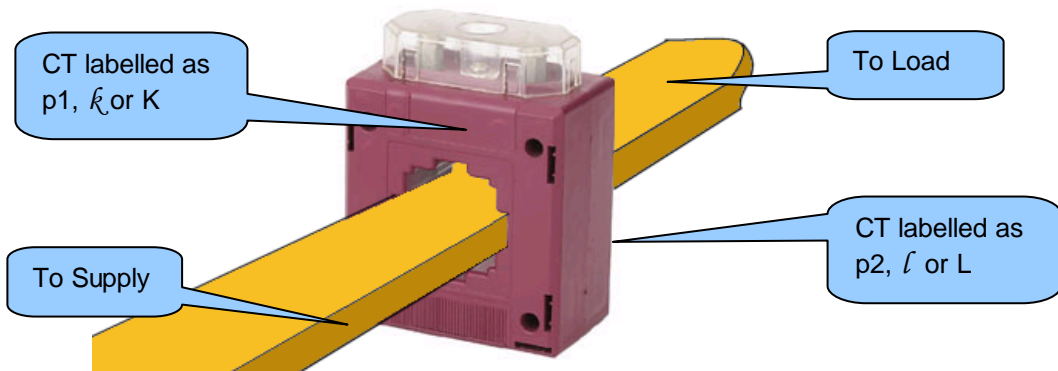

4.2.7 CONFIGURABLE DIGITAL INPUTS

	PIN No	DESCRIPTION	CABLE SIZE	NOTES
	60	Configurable digital input A	0.5mm ² AWG 20	Switch to negative
	61	Configurable digital input B	0.5mm ² AWG 20	Switch to negative
	62	Configurable digital input C	0.5mm ² AWG 20	Switch to negative
	63	Configurable digital input D	0.5mm ² AWG 20	Switch to negative
	64	Configurable digital input E	0.5mm ² AWG 20	Switch to negative
	65	Configurable digital input F	0.5mm ² AWG 20	Switch to negative
	66	Configurable digital input G	0.5mm ² AWG 20	Switch to negative
	67	Configurable digital input H	0.5mm ² AWG 20	Switch to negative
	68	Configurable digital input I	0.5mm ² AWG 20	Switch to negative

 **NOTE:- Terminal 69 is not fitted to the DSE7510 MK1 controller.**

4.2.8 PC CONFIGURATION INTERFACE CONNECTOR

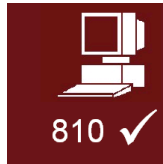

8-way connector allows connection to PC via 810 configuration interface. Module can then be re-configured utilising the 5xxx for Windows™ software.

 **CAUTION!:** This socket must not be used for any other purpose.

4.2.9 EXPANSION INTERFACE CONNECTOR



4-way connector allows connection to the P130 input expansion, P157 relay expansion module or 545/548 LED expansion modules.

A maximum of 2 relay or LED expansion modules may be connected in series to this port.

 **CAUTION! - Do not connect the 808 configuration interface to this port, as it is not possible to use the 808 software to configure the 7510MK1 module.**

 **CAUTION!:** This socket must not be used for any other purpose.

4.2.10 RS485 CONNECTOR

The module is fitted with RS485 AND RS232 as standard. Only one port can be selected at a time (selectable in the 75xx configuration software). Additionally if the 810 port is 'active', the RS485 port is disabled until the 810 ports becomes 'inactive' again.

PIN No	NOTES
A	Two core screened twisted pair cable. 120Ω impedance suitable for RS485 use.
B	Recommended cable type - Belden 9841
SCR	Max distance 1000m (1km) when using Belden 9841 or direct equivalent.

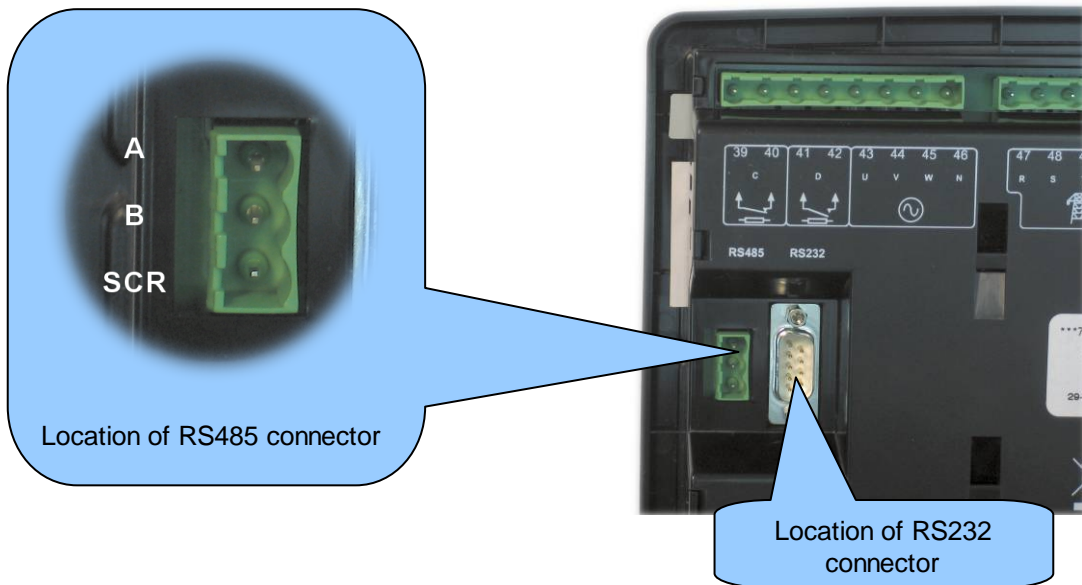

4.2.11 RS232 CONNECTOR

The module is fitted with RS485 AND RS232 as standard. Only one port can be selected at a time (selectable in the 75xx configuration software). Additionally if the 810 port is 'active', the RS485 port is disabled until the 810 ports becomes 'inactive' again.

PIN No	NOTES
1	Received Line Signal Detector (Data Carrier Detect)
2	Received Data
3	Transmit Data
4	Data Terminal Ready
5	Signal Ground
6	Data Set Ready
7	Request To Send
8	Clear To Send
9	Ring Indicator

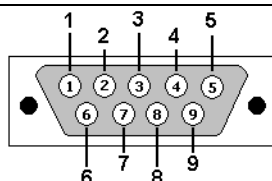

View looking into the male connector on the 7000 series module

4.2.12 ENGINE CONTROL UNIT INTERFACE

The module is capable of interfacing with the ECU fitted to electronically controlled engines. Different manufacturers of engines utilise various different interfaces and protocols. As this is a rapidly developing area, we recommend checking with DSE Support as to which engines are currently supported.

The module will monitor the engines operating parameters such as engine speed, oil pressure, engine temperature (among others) in order to closely monitor and control the engine. The data gathered by the engine controller is transmitted via an industry standard communications interface. This allows generator controllers such as the DSE 75xxMK1 range to access these engine parameters with no physical connection to the sensor device.

Utilising the technology present on the engine in this way gives fewer connections to the engine, higher reliability and better diagnosis of engine related problems.

 **NOTE:- For further details for connections to electronic engines refer to the manual CAN and DSE Wiring. Part No. 057-004**

4.2.13 LED INDICATORS AND LOGO INSERT

USER CONFIGURABLE LED's

These LEDs can be configured by the user to indicate any one of **100+ different functions** based around the following:-

- **INDICATIONS** - Monitoring of a digital input and indicating associated functioning user's equipment - *Such as Battery Charger On or Louvre Open, etc.*
- **WARNINGS** and **SHUTDOWNS** - Specific indication of a particular warning or shutdown condition, backed up by LCD indication - *Such as Low Oil Pressure Shutdown, Low Coolant level, etc.*
- **STATUS INDICATIONS** - Indication of specific functions or sequences derived from the modules operating state - *Such as Safety On, Pre-heating, Panel Locked, Generator Available, etc.*

These LEDs are annunciated using a removable insert card. Additionally the module's logo can be changed to suit generator manufacturer's requirements. This can be used for instance to give custom branding to the module, or even include the service telephone number.

DSE have produced the 'insert card creator' software, shipped with the DSE SoftwareCD to ease the production of text and logo insert cards to suit your application.

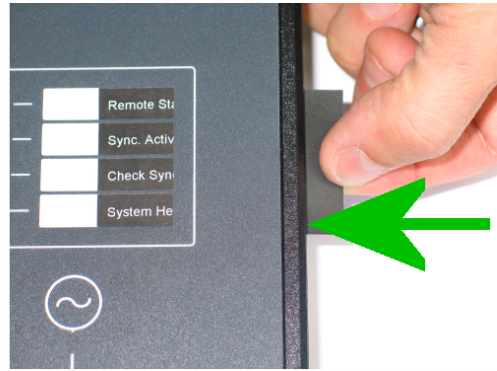

Removal and insertion of the LED text insert card

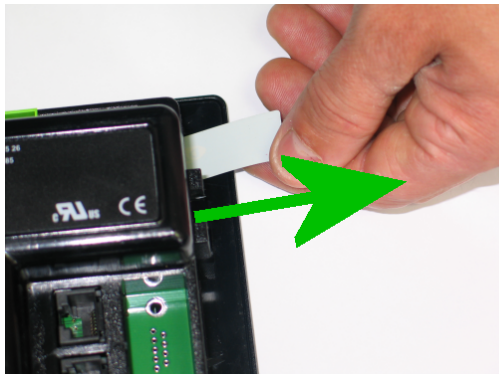

Removal and insertion of the Logo insert card

5 OPERATION

5.1 CONTROL

Control of the **DSE 7510MK1** module is via push buttons mounted on the front of the module with **STOP/RESET**, **MANUAL**, **AUTO**, **ALARM MUTE/LAMP TEST** and **START** functions. For normal operation these are the only controls which need to be operated. The smaller push buttons are used to access further information such as engine instruments and load switching. Detail of their operation is covered later in this document.

The following descriptions detail the sequences followed by a module containing the standard 'factory configuration'. Always refer to your configuration source for the exact sequences and timers observed by any particular module in the field.







 **CAUTION:** - The module may instruct an engine start event due to external influences. Therefore, it is possible for the engine to start at any time without warning. Prior to performing any maintenance on the system, it is recommended that steps are taken to remove the battery and isolate supplies.

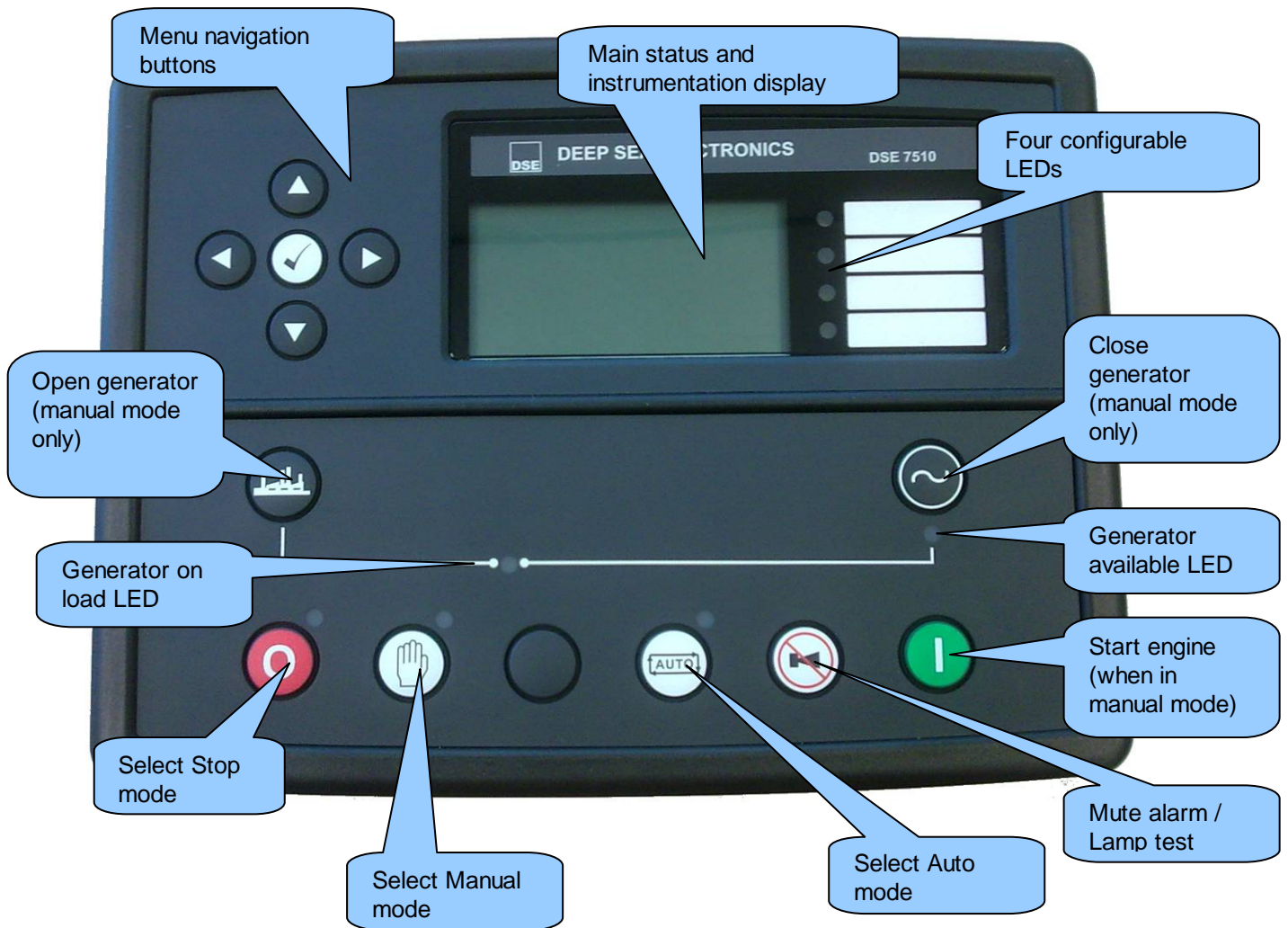

5.1.1 DESCRIPTION OF CONTROLS

The following section details the function and meaning of the various controls on the module.



6 CONTROL PUSH-BUTTONS

<p>STOP/RESET</p> <p>This push-button places the module into its Stop/reset mode. This will clear any alarm conditions for which the triggering criteria have been removed. If the engine is running and this push-button is operated, the module will automatically instruct the generator contactor/breaker to unload the generator. The fuel supply will be removed and engine will be brought to a standstill. Should a remote start signal be present while operating in the mode, a remote start will <u>not</u> occur.</p>	
<p>MANUAL</p> <p>This push-button is used to allow manual control of the generator functions. Entering this mode from another mode will initially not cause any change of operating state, but allows further push-buttons to be used to control the generator operation. For example, once in Manual mode it is possible to start the engine by using the 'START' push-button. If the engine is running, off-load in the Manual mode and a remote start signal becomes present, the module will automatically instruct the generator contactor/breaker device to place the generator on load. Should the remote start signal then be removed the generator will remain on load until either the 'STOP/RESET' or 'AUTO' push-buttons are operated.</p>	
<p>START</p> <p>This push-button is used to start the engine. The module must first be placed in the 'MANUAL' mode of operation. The 'START' button should then be operated. The engine will then automatically attempt to start. Should it fail on the first attempt it will re-try until either the engine fires or the pre-set number of attempts have been made. To stop the engine the 'STOP/RESET' button should be operated. It is also possible to configure the module such that the start push-button must be held to maintain engine cranking.</p>	
<p>NOTE:- Different modes of operation are possible - Please refer to your configuration source for details.</p>	
<p>AUTO</p> <p>This push-button places the module into its 'Automatic' mode. This mode allows the module to control the function of the generator automatically. The module will monitor the remote start input and once a start condition is signalled the set will be automatically started and placed on load. If the starting signal is removed, the module will automatically transfer the load from the generator and shut the set down observing the stop delay timer and cooling timer as necessary. The module will then await the next start event. <i>For further details, please see the more detailed description of 'Auto Operation' earlier in this manual.</i></p>	
<p>ALARM MUTE</p> <p>This push-button is used to silence the internal alarm sounder and also any external sounder devices fed from the audible alarm output. Any further alarm conditions will reactivate the sounder. Once the alarm has been muted and investigated, it may then be cleared. <i>Refer to the 'Protections' section of this manual for details.</i></p> <p>When the Alarm Mute is operated a Lamp test function will also be implemented and all LED indicators will be illuminated.</p>	

<p>CLOSE GENERATOR</p> <p>This push button is used to control the closure of the generator load switching device and has two modes of operation :</p> <ol style="list-style-type: none"> 1. Synchronising is NOT enabled. Pressing this button when the generator is running off load and in MANUAL mode, the generator load switch is closed. Further presses of this button will have no effect. 2. Synchronising is enabled. Pressing this button when the generator is running and in MANUAL mode, the 7510MK1 controller, will volts match and synchronise with the Bus. The generator load switch is then closed in parallel with the Bus. <p>▲ NOTE:- This button is only active in MANUAL mode.</p> <p>▲ NOTE:- If the bus is live when the manual button is pressed, synchronising will take place before the load switch is closed.</p>	
<p>OPEN GENERATOR</p> <p>This push button is used to control the opening of the generator load switching device</p> <p>Pressing this button when the generator is running on load, and in MANUAL mode, the generator load switch is opened. Further presses of this button will have no effect.</p> <p>▲ NOTE:- This button is only active in MANUAL mode.</p>	
<p>Menu navigation</p> <p>Used for navigating the instrumentation, event log and configuration screens. For further details, please see the more detailed description of these items elsewhere in this manual.</p>	

6.1 AUTOMATIC MODE OF OPERATION

Automatic mode is used to start the set in response to an external start requirement from another device.

A number of options exist for the remote start input (selectable using 5xxx configuration software).

- Remote Start on Load input indicates to the controller that it should start the set, and run 'off load'.
- Remote Start on Load input indicates to the controller that it should start the set, synchronise (if required) and share load with any other sets in the system.
- Remote Start on Load Demand input indicates to the controller that it should start the sets, synchronise (if required) and share load with any other sets in the system, automatically starting and stopping sets on changing load demand.

NOTE: - If a digital input configured to panel lock is active, changing module modes will not be possible. Viewing the instruments  and event log is NOT affected by panel lock. If panel lock is active the Panel lock indicator (if configured) illuminates.

This mode is activated by pressing the  pushbutton. An LED indicator beside the button will illuminate to confirm this operation.

Should the remote start input (if configured) become active then the following sequence is observed.

To allow for short term or false remote start signals, the Start Delay timer is initiated. After this delay, if the pre-heat output option is selected then the pre-heat timer is initiated and the corresponding auxiliary output (if configured) will energise.

NOTE:- If the Remote Start signal is removed during the Start Delay timer, the unit will return to a stand-by state.

After the above delays the **Fuel Solenoid (or enable ECU output if configured)** is energised, then one second later, the **Starter Motor** is engaged.

NOTE:- If the unit has been configured for CAN Bus, compatible ECU's will receive the start command via CAN Bus. Refer to the Manual CAN and DSE Wiring. Part No. 057-004 for more information on utilising DSE modules with electronically controlled engines.

The engine is cranked for a pre-set time. If the engine fails to fire during this cranking attempt then the starter motor is disengaged for the pre-set rest period. Should this sequence continue beyond the set number of attempts, the start sequence will be terminated and **Fail to Start** fault will be displayed.

Alarm
Shutdown
Failed to start

When the engine fires, the starter motor is disengaged and locked out at a pre-set frequency measured from the alternator output. Alternatively, a Magnetic Pickup mounted on the flywheel housing can be used for speed detection (This is selected by PC using the 5xxx series configuration software). Rising oil pressure can also be used to disconnect the starter motor, however it cannot be used for underspeed or overspeed detection.

 **NOTE:- If the unit has been configured for use with an electronic engine, speed sensing is via the data-link.**

After the starter motor has disengaged, the **Safety On** timer is activated, allowing Oil Pressure, High Engine Temperature, Under-speed, Charge Fail and any delayed Auxiliary fault inputs to stabilise without triggering the fault.

If the system has been started by a '**remote start off load**' input, the set will run '**off load**'. Otherwise, the **Warm Up** timer, if selected, is initiated, allowing the engine to stabilise. After the **Warm-up** timer has expired then the module will close the load switching device.

In the case of a single generator system, the **Generator Contactor/Breaker** will be instructed to close. The generator will then supply the requirements of the load.

On a multi-set system, if the common generator bus is live, the 7510MK1 module will first synchronise the generator to the bus before closing the **Generator Contactor/Breaker**. A 'token' is held by the module that first closed onto the dead bus and as only one token exists for each multi-set system, this prevents other sets in the system from attempting to close their own breakers.

For added security, the modules also monitor the bus. If this is found to be live, then the synchronisation process begins.

Once the load switching device is closed, the 7510MK1 will then ramp to share the load with the other generators in the system.

 **NOTE:-A load transfer will not be initiated until the Oil Pressure has risen. This prevents excessive wear on the engine.**

When the **Remote start** signal is removed, the **Stop** delay timer is initiated. Once this has expired, the module will ramp the load from the generator to remaining set (Multi-set systems only). The Generator Contact/Breaker will open and the **Cooling** timer is then initiated, allowing the engine a cooling down period off load before shutting down. Once the **Cooling** timer expires, the **Fuel Solenoid** is de-energised, bringing the generator to a stop.

For full details of multi-set operation please refer to the manual 'The Guide to sync and load share Pt1'

Should the **Remote Start** signal be re-activated during the cooling down period, the set will return on load.



 **NOTE:- When synchronising is enabled, the bus is checked before closing any load switching device. If the bus is live, synchronising will take place before any closure takes place.**

 **NOTE:- Synchronising can be disabled if the application does not require this function. Contact your genset supplier in the first instance for further details.**

 **NOTE:-** The internal 'Scheduler' can be configured to operate the system in the same manner as described for the Remote start input. Please refer to the 5xxx Configuration Software manuals for full details on the feature.

6.2 MANUAL OPERATION

Manual mode is used to allow the operator to control the operation of the generator, and to provide fault finding and diagnostic testing of the various operations normally performed during Automatic mode operation.

 **NOTE:-** If a digital input configured to panel lock is active, changing module modes will not be possible. Viewing the instruments  and event logs is NOT affected by panel lock. If panel lock is active the Panel lock indicator (if configured) illuminates.

MANUAL, mode is selected by pressing the  pushbutton. An LED besides the button will illuminate to confirm this operation. When the **START** (I) button is operated, the module will initiate the start sequence.

 **NOTE: -** There is no Start Delay in this mode of operation.

If the **pre-heat** output option has been selected, this timer will be initiated and the auxiliary output selected energised.

After the above delay, the **Fuel Solenoid (or ECU output if configured)** is energised, and then one second later, the **Starter Motor** is engaged.

 **NOTE:-** If the unit has been configured for CAN Bus, compatible ECU's will receive the start command via CAN Bus. Refer to the Manual CAN and DSE Wiring. Part No. 057-004 for more information on utilising DSE modules with electronically controlled engines.

The engine is cranked for a pre-set time. If the engine fails to fire during this cranking attempt then the starter motor is disengaged for the pre-set rest period. Should this sequence continue beyond the set number of attempts, the start sequence will be terminated and **Fail to Start** will be displayed.

Alarm
Shutdown
Fail to start

When the engine fires, the starter motor is disengaged and locked out at a pre-set frequency measured from the Alternator output. Alternatively, a Magnetic Pickup mounted on the flywheel housing can be used for speed detection (This is selected by PC using the 5xxx series configuration software). Rising oil pressure can also be used to disconnect the starter motor; however, it cannot be used for underspeed or overspeed detection.

 **NOTE:-** If the unit has been configured for CAN Bus, speed sensing is via CAN Bus.

After the starter motor has disengaged, the **Safety On** timer is activated, allowing Oil Pressure, High Engine Temperature, Under-speed, Charge Fail and any delayed Auxiliary fault inputs to stabilise without triggering the fault.

Once the engine is running, the **Warm Up** timer (if selected) is initiated, allowing the engine to stabilise before it can be loaded. Once the warm up timer has expired the generator is then available to go on load and the **Generator Available LED** will illuminate on the front panel.



If the DSE7510 has been configured and connected to a compatible generator manual speed / voltage control is possible using the “running editor” when the engine is running and the breaker is open. Details of this can be found in the section entitled “running editor” elsewhere in this manual.

The generator will run off load unless:

1. A **Remote Start on load** signal is applied
2. An on-load run is configured in the scheduler.
3. The  **Close Generator** button is pressed.

On a multi-set system, if the common generator bus is live, the 7510MK1 module will first synchronise the generator to the bus before closing the **Generator Contactor/Breaker** to close. A ‘token’ is held by the module that first closed onto the dead bus and as only one token exists, this prevents other sets in the system from attempting to close their own breakers. For added security, the modules also monitor the bus. If this is found to be live, then the synchronisation process begins.

During the parallel run the module can be configured to either run at a fixed level output, such as when used in parallel with an infinite bus. Alternatively, it can be configured to load share with other generators on the bus. For full details of these mode please refer to the manual ‘The Guide to sync and load share Pt1’

- If the **Open Generator**  button is pressed while in parallel, the module will ramp the load off the generator and then open the generator contactor/breaker.
- If the **Open Generator**  button is pressed and the generator is connected to the common generator bus then the load is ramped off the generator and the contactor/breaker is opened.

If **Auto** mode is selected and the remote start on load signal not active, and the scheduler is not calling for a run, then the **Return Delay Timer** will start.

Once this has expired then the module will exit **parallel** operation and will ramp the load back to the remaining generators. It will then open the **Generator Contactor/Breaker**. The generator will then run **off** load allowing the engine a **cooling** period.

Selecting **STOP (O)** de-energises the **FUEL SOLENOID**, bringing the generator to a stop.

 **WARNING:** - Operation of the **STOP** button in any mode will stop the generator operation and return the load switching system to a safe state. This operation may lead to loss of supply to the load. It is recommended that the **STOP** button is only operated once the generator is **OFF LOAD** and the mains supply provides power to the load.





 **NOTE:** - Synchronising can be disabled if the application does not require this function. Contact your genset supplier in the first instance for further details.

 **NOTE:** - When synchronising is enabled, the bus is checked before closing any load switching device. If the bus is live, synchronising will take place before any closure takes place.

 **NOTE:** - Upon closing the load switching device, the module checks that the bus becomes live. If it does not, an alarm is generated to indicate the problem.







6.2.1 MANUAL FUEL PUMP CONTROL

 **NOTE:-Manual Fuel Pump Control is only available on suitably configured systems with V3 or higher control modules. Consult your set supplier for further advice.**

- Navigate to the instruments page using the  buttons and locate FUEL LEVEL.  is shown on the module display to indicate that this feature is available.
- Press and hold the  button to energise the transfer pump. The pump starts two seconds after the button is pressed.
- Release the  button to de-energise the transfer pump.

6.2.2 MANUAL SPEED CONTROL

 **NOTE:-Manual Speed Control is only available on suitably configured systems with V3 or higher control modules. Consult your set supplier for further advice.**

- Navigate to the instruments page using the  buttons and locate ENGINE SPEED.  is shown on the module display to indicate that this feature is available.
- Press the  button to enter edit mode
- Press  (up) or  (down) to change the engine speed.
- Press the  button again to exit the editor and leave the engine running at the newly selected speed.

7 PROTECTIONS

When an alarm is present the Audible Alarm will sound and the Common alarm LED (if configured) will illuminate.

The audible alarm can be silenced by pressing the **'Mute'** button



The LCD display will jump from the 'Information page' to display the Alarm Page

Alarm	
Warning	← The type of alarm. Shutdown or warning
Low oil pressure	← The nature of alarm, e.g. Low oil pressure.

The LCD will display multiple alarms e.g. "High Engine Temperature shutdown", "Emergency Stop" and "Low Coolant Warning" alarms that may have been triggered. These will automatically scroll round in the order that they occurred.

In the event of a warning alarm the LCD will display the appropriate text. If a shutdown then occurs the module will again display the appropriate text.
Example:-

Alarm
Shutdown High coolant temp

Followed by....

Alarm
Shutdown Emergency stop

Followed by....

Alarm
Warning Low coolant level

The unit will scroll through all active alarms in a continuous loop.

Alarm
Shutdown High coolant temp

Generator available	
L-N 229v	0A
L-L 400 v	50.0Hz
Pf 0.00	0KW

If no alarms are present the LCD will display this default page.

7.1 WARNINGS

Warnings are non-critical alarm conditions and do not affect the operation of the generator system. They draw the operators' attention to an undesirable condition.

In the event of an alarm the LCD will jump to the alarms page and scroll through all active warnings and shutdowns.

BATTERY CHARGE FAILURE	Displayed if the module does not detect a voltage from the warning light terminal on the auxiliary charge alternator.
BATTERY LOW VOLTAGE	Displayed if the module detects that the plant DC supply has fallen below the low volts setting level. The Battery Low Voltage alarm is delayed by the Low DC Volts Delay timer.
BATTERY HIGH VOLTAGE	Displayed if the module detects that the plant DC supply has risen above the high volts setting level. The Battery High Voltage alarm is delayed by the High DC Volts Delay timer.
FAIL TO STOP	<p>Displayed if the module detects the engine is still running when the 'Fail to stop timer' expires.</p> <div style="border: 1px solid black; padding: 5px;"> <p>⚠NOTE:- 'Fail to Stop' could indicate a faulty oil pressure SENSOR - If engine is at rest check oil SENSOR wiring and configuration.</p> </div>
AUXILIARY INPUTS	Auxiliary inputs can be user configured and will display the message as configured in the module.
LOW FUEL LEVEL	Displayed if the fuel level detected by the fuel level SENSOR falls below the low fuel level setting.
LOW ENGINE TEMPERATURE	If the module detects that the engine coolant temperature has fallen below the low engine temperature pre-alarm setting level, a warning will occur. Alarm Warning Low Coolant Temp will be displayed.
GENERATOR HIGH CURRENT	If the module detects a generator output current in excess of the pre-set trip a warning is initiated. Alarm Warning High Current will be displayed. If this high current condition continues for an excess period of time, then the alarm is escalated to a shutdown or electrical trip condition (if configured) . For further details of the high current alarm, please see Delayed Overcurrent Shutdown / Electrical Trip Alarm.
GENERATOR FAILED TO OPEN	If the module requests the generator contact/breaker to open it will monitor the auxiliary contacts for feedback that this has happened. If the feedback does not confirm the action within the Generator breaker open timer, then the following alarm will occur.

MAINTENANCE DUE	The module can be configured to monitor either engine running hours or absolute time, or both. Should either of these values exceed the pre-set service interval the following alarm will occur.
FAILED TO SYNCHRONISE	If the module cannot synchronise within the timer allowed by the Synchronising timer a warning is initiated. The LCD will indicate ' FAILED TO SYNC '.
GENERATOR PHASE SEQUENCE WRONG	if the module detects a phase rotation error, a warning is initiated
BUS PHASE SEQUENCE WRONG	the module detects a bus phase rotation error a warning is initiated.
NEGATIVE PHASE SEQUENCE	If the module detects an imbalance in the load current of each phase above a pre-set level, then the following warning will occur.
MSC DATA ERROR	If the module detects a problem on the MSC link which prevents the module from communicating correctly with the other modules, then the MSC Data Error alarm will be triggered. Incorrect wiring type or connection may be a possibility.
MSC TOO FEW SETS	If the module detects fewer modules on the MSC link than the minimum number configured in the unit the MSC Too few sets alarm will be triggered. This may indicate a break in the MSC connection between the sets.
CAN ECU WARNING	If the module is configured for use with an electronic engine and receives a Warning (Yellow Lamp) message from the engine control unit, 'Can ECU warning' is shown on the module's display and a warning alarm is generated.
LOSS OF EXCITATION	The module will monitor the KVA _r present on the generator. Should this exceed a pre-set amount of negative VA _r this indicates a possible loss of excitation on the alternator. The following alarm will then be generated.
kW OVERLOAD ALARM	The kW level provided by the set is above the level of the kW Overload pre alarm
ENGINE INLET TEMPERATURE	The engine inlet temperature (electronic engines only) is above the level of the Engine Inlet Temperature alarm.
AVR TRIM LIMIT	The analogue AVR output is being instructed to provide 100% of its capacity. This can indicate control problems with the AVR or excessive reactive load.

7.2 ANALOGUE PRE-ALARMS

The following alarms are termed 'pre-alarms' as they pre-warn the operator of a potentially more serious alarm condition. For instance, if the engine temperature rises past the pre alarm level, a warning condition will occur to notify the operator. If the temperature falls below this level, then the alarm ceases and the set will continue to run as normal. However if the temperature continues to rise until the coolant temperature trip point is reached, the warning is escalated and a high coolant temperature shutdown is initiated.

LOW OIL PRESSURE	If the module detects that the engine oil pressure has fallen below the low oil pressure pre-alarm setting level after the Safety On timer has expired, a warning will occur. Alarm Warning Low Oil Pressure will be displayed.
HIGH ENGINE TEMPERATURE	If the module detects that the engine coolant temperature has exceeded the high engine temperature pre-alarm setting level after the Safety On timer has expired, a warning will occur. Alarm Warning High Coolant Temperature will be displayed.
OVERSPEED	If the engine speed exceeds the pre-alarm trip a warning is initiated. Alarm Warning Overspeed will be displayed. It is an immediate warning .
UNDERSPEED	If the engine speed falls below the pre-set pre-alarm after the Safety On timer has expired, a warning is initiated. Alarm Warning Underspeed will be displayed.
GENERATOR HIGH FREQUENCY	If the module detects a generator output frequency in excess of the pre-set pre-alarm, a warning is initiated. Alarm Warning High frequency will be displayed, it is an immediate warning .
GENERATOR LOW FREQUENCY	If the module detects a generator output frequency below the pre-set pre-alarm after the Safety On timer has expired, a warning is initiated. Alarm Warning Low Frequency will be displayed
GENERATOR HIGH VOLTAGE	If the module detects a generator output voltage in excess of the pre-set pre-alarm, a warning is initiated. Alarm Warning High voltage will be displayed, it is an immediate warning .
GENERATOR LOW VOLTAGE	The module detects a generator output voltage below the pre-set pre-alarm after the Safety On timer has expired, a warning is initiated. Alarm Warning Low Voltage will be displayed.
AVR TRIM LIMIT	The analogue AVR output is being instructed to provide 100% of its capacity. This can indicate control problems with the AVR or excessive reactive load.

7.3 SHUTDOWNS

Shutdowns are latching and stop the Generator. The alarm must be cleared and the fault removed to reset the module.

▲ NOTE:- The alarm condition must be rectified before a reset will take place. If the alarm condition remains it will not be possible to reset the unit (The exception to this is the Low Oil Pressure alarm and similar ‘delayed alarms’, as the oil pressure will be low with the engine at rest).

FAIL TO START	If the engine does not fire after the pre-set number of attempts has been made a shutdown will be initiated. Alarm Shutdown Fail To Start will be displayed.
EMERGENCY STOP	Removal of the positive DC Supply from the Emergency Stop input will initiate a shutdown of the Generator and prevent any attempt to restart the Generator until the Emergency Stop push-button has been reset. Additionally it removes the positive DC supply from both the Fuel Solenoid and Starter Solenoid.
	▲ NOTE:- The Emergency Stop positive signal must be present otherwise the unit will shutdown.
LOW OIL PRESSURE	If the module detects that the engine oil pressure has fallen below the low oil pressure trip setting level after the Safety On timer has expired, a shutdown will occur. Alarm Shutdown Low Oil Pressure will be displayed.
HIGH ENGINE TEMPERATURE	If the module detects that the engine coolant temperature has exceeded the high engine temperature trip setting level after the Safety On timer has expired, a shutdown will occur. Alarm Shutdown High Engine Temperature will be displayed.
OVERSPEED	If the engine speed exceeds the pre-set trip a shutdown is initiated. Alarm Shutdown Overspeed will be displayed. Overspeed is not delayed, it is an immediate shutdown .
	▲ NOTE:- During the start-up sequence the overspeed trip logic can be configured to allow an extra trip level margin. This is used to prevent nuisance tripping on start-up - Refer to the 75xxMK1 series configuration software manual under heading ‘Overspeed Overshoot’ for details.
UNDERSPEED	If the engine speed falls below the pre-set trip after the Safety On timer has expired, a shutdown is initiated. Alarm Shutdown Underspeed will be displayed.
GENERATOR HIGH FREQUENCY	If the module detects a generator output frequency in excess of the pre-set trip a shutdown is initiated. Alarm Shutdown High Frequency will be displayed, it is an immediate shutdown .
GENERATOR LOW FREQUENCY	If the module detects a generator output frequency below the pre-set trip after the Safety On timer has expired, a shutdown is initiated. Alarm Shutdown Low Frequency will be displayed.

GENERATOR HIGH VOLTAGE	If the module detects a generator output voltage in excess of the pre-set trip a shutdown is initiated. Alarm Shutdown High Volts will be displayed, it is an immediate shutdown .
GENERATOR LOW VOLTAGE	If the module detects a generator output voltage below the pre-set trip after the Safety On timer has expired, a shutdown is initiated. Alarm Shutdown Low Volts will be displayed. <div style="border: 1px solid black; padding: 5px;"> <p>⚠ NOTE:-Generator voltage and frequency alarms can be delayed by the ‘Gen Transient ignore’ timer. This is to prevent nuisance tripping when applying or removing load on the generator.</p> </div>
OIL PRESSURE SENSOR OPEN CIRCUIT	If the module detects a loss of signal from the oil pressure SENSOR (open circuit) a shutdown is initiated. Alarm Shutdown SENSOR Fault will be displayed. SENSOR failure is not delayed, it is an immediate shutdown .
MAGNETIC PICKUP OPEN CIRCUIT	The module detects a problem with the connection to the magnetic pickup (open circuit) a shutdown is initiated. MPU failure is not delayed, it is an immediate shutdown .
AUXILIARY INPUTS	If an auxiliary input has been configured as a shutdown the appropriate message will be displayed as configured by the user.
LOSS OF SPEED SIGNAL	If the speed sensing signal is lost during cranking, a shutdown is initiated. Alarm Shutdown Loss of Speed Signal will be displayed. <div style="border: 1px solid black; padding: 5px;"> <p>⚠ NOTE:- This will only occur if the magnetic pickup speed sensing signal is lost during cranking or during the safety on timer. If the signal is lost during normal operation the Generator will shutdown with an Under-speed alarm.</p> </div>
CAN DATA FAIL	If the module is configured for CANbus operation and does not detect data on the engine CANbus datalink, a shutdown will occur and ‘Can data fail’ is shown on the module’s display.
CAN ECU SHUTDOWN	If the module is configured for CANbus operation and receives a “Shutdown” (Red Lamp) message from the engine control unit, the engine is shutdown and ‘Can ECU Shutdown’ is shown on the module’s display.
GENERATOR HIGH CURRENT	For Details see the section entitled “Delayed Overcurrent Alarm” elsewhere in this manual.



⚠ NOTE: - If the CAN message is a manufacturers specific code, it may not be displayed as text. If this is the case, the display will show the generic manufacturers code only, which must be cross-referenced with the engine manufacturer’s literature. Please contact the engine manufacturer for further assistance.

The above displays show a standard J1939 based system. Other manufacturers systems supported by the module work in a similar way though the exact detail may vary from those illustrated.

Example
Alarm
Can ECU fail
SPNnnnnn
FMInnnn

GENERATOR EARTH FAULT	If the module detects a generator earth fault current in excess of the pre-set trip a shutdown is initiated. The LCD will indicate ' EARTH FAULT '. This alarm is configurable between Warning, Shutdown and Electrical Trip. "Shutdown" is the factory default setting. See the section entitled "Earth Fault and Short Circuit Tripping Curves" for details of module reaction.
AIR FLAP CLOSED	If the module detects feedback to indicate that the engine air intake flap is closed a shutdown alarm will be initiated.
NEGATIVE PHASE SEQUENCE	If the module detects an imbalance in the load current of each phase above a pre-set level, then the following warning will occur.
MSC OLD UNITS ON BUS	If the module detects a module on the MSC link which is incompatible with the current module, then the MSC Compatibility alarm will be triggered. Check the configuration (using 5xxx configuration software) to ensure correct MSC mode is selected (Extended functionality / Pre version 6 compatibility) Incompatible modules without configurable MSC mode will need to be replaced with compatible units.
MSC ID ERROR	All modules on the MSC link must have a unique ID number. On later modules, ID's are automatically assigned when joining the MSC link. On modules prior to version 5.00, the ID must be set using 5xxx configuration software.
MSC FAILURE	If the module is unable to detect the MSC link then the MSC Failure alarm will be triggered. Incorrect wiring type or connection may be a possibility.
LOSS OF EXCITATION	The module will monitor the KVAR present on the generator. Should this exceed a pre-set amount of negative VAR this indicates a possible loss of excitation on the alternator. The following alarm will then be generated.
KW OVERLOAD	The kW level provided by the set is above the level of the kW Overload Shutdown level
ENGINE INLET TEMPERATURE	The engine inlet temperature (electronic engines only) is above the level of the Engine Inlet Temperature alarm.
AVR TRIM LIMIT	The analogue AVR output is being instructed to provide 100% of its capacity. This can indicate control problems with the AVR or excessive reactive load.

7.4 ELECTRICAL TRIPS

Electrical trips are latching and stop the Generator but in a controlled manner. On initiation of the electrical trip condition the module will de-energise the '**Close Generator**' Output to remove the load from the generator. Once this has occurred the module will start the Cooling timer and allow the engine to cool off-load before shutting down the engine. The alarm must be accepted and cleared and the fault removed to reset the module.

AUXILIARY INPUTS	If an auxiliary input has been configured as an electrical trip the appropriate message will be displayed as configured by the user.
GENERATOR HIGH CURRENT	For Details see the section entitled "Delayed Overcurrent Alarm" elsewhere in this manual.
GENERATOR REVERSE POWER	If the module detects a generator reverse power current in excess of the pre-set trip a shutdown is initiated. The LCD will indicate ' GEN REVERSE POWER '.
GENERATOR SHORT CIRCUIT	If the module detects a generator fault current in excess of the pre-set trip a shutdown is initiated. The LCD will indicate ' GEN SHORT CIRCUIT '. See the section entitled "Earth Fault and Short Circuit Tripping Curves" for details of module reaction.
LOSS OF EXCITATION	The module will monitor the KVA _r present on the generator. Should this exceed a pre-set amount of negative Var this indicates a possible loss of excitation on the alternator. The following alarm will then be generated.
NEGATIVE PHASE SEQUENCE	If the module detects an imbalance in the load current of each phase above a pre-set level, then the following warning will occur.
kW OVERLOAD	The kW level provided by the set is above the level of the kW Overload Electrical Trip level
ENGINE INLET TEMPERATURE	The engine inlet temperature (electronic engines only) is above the level of the Engine Inlet Temperature alarm.
AVR TRIM LIMIT	The analogue AVR output is being instructed to provide 100% of its capacity. This can indicate control problems with the AVR or excessive reactive load.

7.5 DELAYED OVERCURRENT SHUTDOWN / ELECTRICAL TRIP ALARM

The delayed overcurrent alarm combines a simple warning trip level with a fully functioning IDMT curve for thermal protection.

7.5.1 IMMEDIATE WARNING

The DSE7500 Series controller generates a *warning alarm* as soon as the *Trip* level is reached. The alarm automatically resets once the generator loading current falls below the *Trip* level (unless *All Warnings are latched* is enabled). For further advice, consult your generator supplier.

7.5.2 IDMT ALARM

If the *Delayed Overcurrent Action* is set to *Shutdown or Electrical Trip*, the DSE7500 Series controller begins following the IDMT 'curve' when the *trip* level is passed.

If the *Trip* is surpassed for an excess amount of time the *Next stage alarm* triggers (*Shutdown or Electric trip* as selected in *Action*).

High current shutdown is a latching alarm and stops the Generator.

Remove the fault then press Stop/Reset  to reset the module.

High current electrical trip is a latching alarm and removes the generator from the load, before stopping the Generator after the off load Cooling timer.

Remove the fault then press Stop/Reset  to reset the module.

The higher the overload, the faster the trip. The speed of the trip is dependent upon the fixed formula :

$$T = t / ((I_A / I_T) - 1)^2$$

Where: T is the tripping time in seconds
 I_A is the actual current of the most highly loaded line (L1 or L2 or L3)
 I_T is the delayed over-current trip point
 t is the time multiplier setting and also represents the tripping time in seconds at twice full load (when I_A / I_T = 2).

The factory settings of 100% trip and time multiplier of 36, provide for normal running of the generator up to 100% full load. If full load is surpassed, the *Immediate Warning* alarm is triggered, the set continues to run.

The effect of an overload on the generator is that the alternator windings begin to overheat, the aim of the *Shutdown or Electrical Trip Alarm* is to prevent the windings being overload (heated) too much. The amount of time that the set can be safely overloaded is governed by how high the overload condition is.

With typical settings as above, the tripping curve shown is followed.

This allows for overload of the set to the limits of the *Typical Brushless Alternator* whereby 110% overload is permitted for 1 hour.

If the set load is reduced, the controller then *follows* a cooling curve. This means that a second overload condition may trip much sooner than the first as the controller *knows* if the windings have not cooled sufficiently.

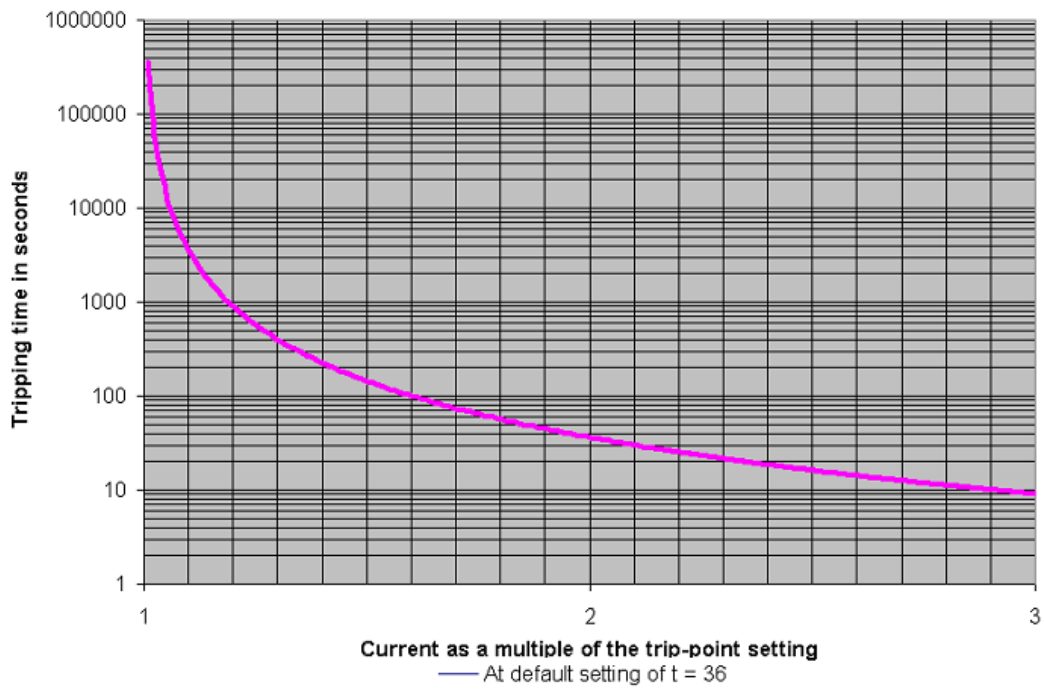

For further details on the *Thermal damage curve* of your alternator, you are referred to your alternator manufacturer and generator supplier.

7.6 EARTH FAULT AND SHORT CIRCUIT TRIPPING CURVES (TYPICAL)

Model 55x Short circuit & Earth fault curves for a
Single phase fault @ 50 Hz

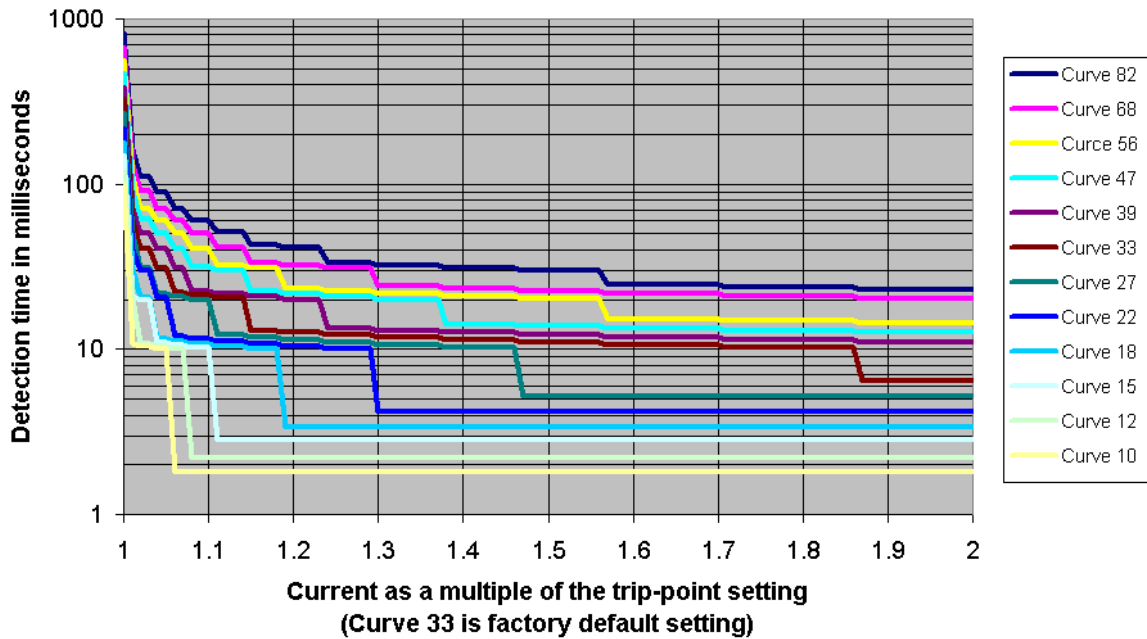



7.7 ROCOF / VECTOR SHIFT

When configured to run in parallel with the mains (utility) supply, the module monitors for ROCOF / Vector shift trips according to the module's configuration settings. This is included within the module and will detect failure of the mains supply during parallel operation with the generator.

NOTE:- This protection operates only when in parallel with the mains supply and is disabled at all other times.

Should either of these alarms operate, the module will perform a controlled shutdown (electrical trip) of the generator. This operation must be manually reset :

- 1) Press  button. The engine will stop if it is still running and the alarm is cleared.
- 2) Activate digital input configured to "Clear ROCOF/Vector shift" if this has been provided.
- 3) Press  and  button together and hold for 5 seconds. The ROCOF/Vector shift instrument is displayed and all 'peak hold' values are reset, clearing the ROCOF/Vector shift alarm.

For details on activating and configuring the ROCOF/Vector shift protection you are referred to the 5xxx for Windows configuration software manual.

7.8 TYPICAL LCD DISPLAY SCREENS

7.8.1 TYPICAL STATUS DISPLAY

Status	Indicates that the module is in Automatic and that the system is in standby. The unit will respond to an active remote start signal.
Waiting in Auto	

Status	Indicates that the module is in automatic and that a start sequence has been initiated, by remote start input. The module is attempting to crank the generator.
Cranking attempt	
2 00.06 Auto mode	

Generator available	If no alarms are present the LCD will display this default page.
L-N 229v 0A	
L-L 400 v 50.0hz	
Pf 0.00 0KW	

7.8.2 TYPICAL INSTRUMENT DISPLAY

Engine oil pressure	The display of the engine oil pressure
6.2 Bar 90 Psi 620 KPa	

Coolant temperature	The display of the engine coolant temperature
74 °C 165 °F	

Generator Amps	The display of all three generator line currents.
L1 50A L2 52A L3 50A	

Mains	ROCOF / Vector shift display (For systems configured to parallel with mains supply only) Present values are shown to the left with the 'peak hold' values shown on the right.
ROCOF 0.2Hz 10Hz Vector 1.4° 2°	

7.8.3 TYPICAL ALARM DISPLAY

Alarm	The module is warning that the engine oil pressure has fallen below a pre set level. The generator is not shutdown.
Warning Low oil pressure	

Alarm	The oil pressure has fallen below a second pre set value and has shutdown the generator.
Shutdown Low oil pressure	

Alarm	The module is warning that the battery voltage is below a pre set value.
Warning Low battery Volts	

7.8.4 TYPICAL EVENT DISPLAY



Event log	1	On the 17 th January 2005 at 16:29 the unit detected a Engine High temperature condition.
17 Jan 2005 16:29:49 Hi Engine temperature		
Event log	2	On the 8 th September 2004 at 20:10. The emergency stop button was pressed and the generator was shutdown.
8 Sep 2004 20:10:05 Emergency stop		
Event log	3	On the 7 th September 2004 at 08:46, the unit detected that the generator output volts exceeded pre-set trip level and has shutdown the generator.
7 Sep 2004 08:46:00 Over Volts Shutdown		

7.9 VIEWING THE INSTRUMENT AND EVENT LOG PAGES

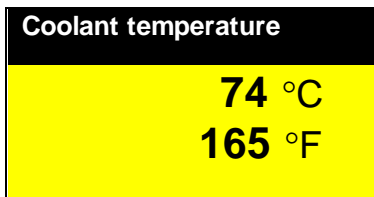
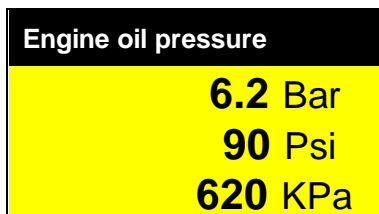
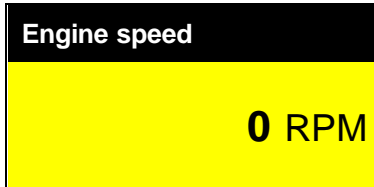
To view a particular instrument, operate the “Page” button  to move to the required page. The LCD will display the page title and then will automatically commence scrolling down the various instruments. On reaching the last instrument, the LCD display will then jump back to the page title and resume scrolling down the page. This sequence will be repeated until either the user moves off the page, the LCD page timer has expired or an alarm condition occurs. In the case of the latter, the module will jump to the alarm page to show the relevant alarm details.



Etc....

It is also possible to scroll to display the different instruments using  and  buttons. Once selected the instrument will remain on the LCD display until the user selects a different instrument or page, or after a period of inactivity, the module will revert to the ‘Status page’.

 **NOTE:-**This description of operation is also true for the other instrument pages and for viewing the records in the event log.

 **NOTE:-** The factory default setting is to show all instruments in a single list. It is possible to change this configuration to a “page” style display using the 5xxx configuration software. When configured to the page style, the instruments are grouped into separate pages – i.e. Engine instruments, Gen instruments, bus instruments.

7.9.1 SYNCHROSCOPE OPERATION

(When enabled)

Display	Detail
	<p>Initial stage of Synchronising display will only show the difference between the Mains Supply and the Generator Output. Here the display is showing a frequency mismatch of +2.9Hz - The genset frequency is too high (indicated by the arrow) and should be reduced. The voltage is +0.2 volts high, but is within the limits set for synchronising.</p>
	<p>Once the difference between the Mains and the Generator frequency has been reduced, the 'Synchroscope' display will become active. The moving bar will roll from one side to the other showing the phase of the two supplies. The area in the centre of the scope indicates the set limits for synchronising to occur.</p>
	<p>Synchronising will only occur when both the Frequency and the voltage differences are within acceptable limits - Indicated by 'Tick' marks on the top of the display. Then the moving bar display will show the phase difference. The engine speed will be automatically adjusted, altering the phase, until the moving bar enters the centre of the scope.</p>
	<p>Once the Mains and generator supplies are synchronised, the module will initiate a breaker close signal to load the generator onto the Mains. Should synchronism be broken the moving bar will pass out of the synchronising window.</p>

▲ Note:-At the start of the synchronising process and if the display is still on the status page, the module will automatically switch to the Synchroscope page. Once the system enters one of the ramping states, the ramp progress will also be displayed on the screen.

▲ NOTE:- If the breaker closing time is too great, then the supplies will drift out of phase before the breaker is closed, an electrical trip alarm will occur and "Out of Sync" will be displayed.

▲ NOTE:- Should the breaker open when on load, and NOT due to a signal from the 7510MK1, the module will detect "Out of Sync" and generate an electrical trip alarm. For instance, this will occur if the breaker is manually opened, or tripped by a device external to the 7510MK1 controller.

7.10 COMPLETE INSTRUMENTATION LIST

7.10.1 BASIC INSTRUMENTATION

Engine Speed
Engine Oil pressure
Coolant temperature
Fuel level
Battery voltage/Charge alt volts
Engine run time/Number of starts
Next maintenance (if enabled)
Generator volts (L1-N, L2-N, L3-N)
Generator volts (L1-L2, L2-L3, L3-L1)
Generator Hz
Generator Amps (L1, L2, L3)
Generator earth current
Generator kW (L1, L2, L3)
Generator total kW/%
Generator kVA (L1, L2, L3)
Generator total kVA/%
Generator pf (L1, L2, L3)
Generator average pf
Generator kVAh (L1, L2, L3)
Generator total kVAh /%
Generator kWh/Generator kVAh/Generator kVAh
Generator phase sequence
Load Demand priority
Synchroscope (when enabled)
Bus volts (L1-N, L2-N, L3-N)
Bus volts (L1-L2, L2-L3, L3-L1)
Bus Hz
Bus phase sequence

7.10.2 ENHANCED ENGINE INSTRUMENTATION



(When supported by the electronic engine ECU)

Engine oil temperature
Coolant pressure
Inlet manifold temperature
Exhaust temperature
Turbo pressure
Fuel pressure
Fuel consumption
Total fuel used





7.11 THE FRONT PANEL CONFIGURATION EDITOR

This configuration mode allows the operator limited customising of the way the module operates.

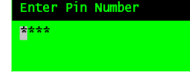
7.11.1 ACCESSING THE FRONT PANEL CONFIGURATION EDITOR.



- Ensure the engine is at rest and the module is in STOP mode by pressing the Stop/Reset  button.
- Press the Stop/Reset  and Info  buttons simultaneously.
- If a module security PIN has been set, the PIN number request is then shown :



- Press  (up) or  (down) to adjust it to the correct value.
- Press  (right) when the first digit is correctly entered. The digit you have just entered will now show '#' for security.
- Repeat this process for the other digits of the PIN number. You can press  (left) if you need to move back to adjust one of the previous digits.
- When  is pressed after editing the final PIN digit, the PIN is checked for validity. If the number is not correct, you must re-enter the PIN.
- If the PIN has been successfully entered (or the module PIN has not been enabled), the editor is displayed :



7.11.2 EDITING A PARAMETER

- Enter the editor as described above.
- Press the left or right buttons to cycle to the section you wish to view/change.
- To edit the parameter, press  to enter edit mode. The parameter begins to flash to indicate that you are editing the value.
- Press the up or down buttons to change the parameter to the required value.
- Press  to save the value. The parameter ceases flashing to indicate that it has been saved.
- To exit the editor at any time, press and hold the  button.

- ▲ NOTE: When the editor is visible, it is automatically exited after 5 minutes of inactivity to ensure security.
- ▲ NOTE: The PIN number is automatically reset when the editor is exited (manually or automatically) to ensure security.
- ▲ NOTE: More comprehensive module configuration is possible using the 75xx series PC configuration software. Please contact us for further details
- ▲ NOTE: The contents of the tables overleaf may differ depending on the actual module configuration.

7.11.3 ADJUSTABLE PARAMETERS

Front Panel Configuration Editor (Factory default settings are shown in bold italicised text)

Section	Parameter as shown on display	Values	
Input settings	Oil Pressure Pre Alarm	0bar - 4bar (1.17bar)	
	Oil Pressure Shutdown	0bar - 4bar (1.03bar)	
	High Coolant Temp Pre Alarm High Coolant Temp Shutdown	80°C - 140°C (115°C) 80°C - 140°C (120°C)	
Timers	Gen Transient Delay	0 - 10s (0s)	
	Start Delay	0 - 60m (5s)	
	Pre Heat Time	0 - 60m (0s)	
	Crank Time	0 - 60s (10s)	
	Crank Rest Time	0 - 60s (10s)	
	Safety On Delay	0 - 30s (10s)	
	Over speed Overshoot Delay	0 - 10s (0s)	
	Warm Up Time	0 - 60m (0s)	
	Return Delay	0 - 60m (30s)	
	Cooling Run Time	0 - 60m (1m)	
	Fail To Stop Delay	0 - 30s (30s)	
	Low Battery Delay	0 - 10m (1m)	
	High Battery Delay	0 - 10m (1m)	
	Gen Reverse Power Delay	0 - 30s (2s)	
Generator	Generator Under Voltage Shutdown	50V-360V ph-N (184V)	
	Generator Under Voltage Pre Alarm	50V-360V ph-N (196V)	
	Generator Nominal Voltage	52V-330V (230V)	
	Generator Over Voltage Pre Alarm	50V-360V ph-N (265V)	
	Generator Over Voltage Shutdown	50V-360V ph-N (277V)	
	Generator Under Frequency Shutdown	0Hz - 75Hz (40Hz)	
	Generator Under Frequency Pre Alarm	0Hz - 75Hz (42Hz)	
	Generator Nominal Frequency	0Hz - 74Hz (50Hz)	
	Generator Over Frequency Pre Alarm	0Hz - 75Hz (55Hz)	
	Generator Over Frequency Shutdown	0Hz - 75Hz (57Hz)	
	Generator Over Current Trip	100% - 200% full load rating (100%)	
	Generator Short Circuit Trip	50% - 300% full load rating (200%)	
	Generator Reverse Power Trip	0% - 200% full load rating (35kW)	
Earth Fault Trip	1% - 100% full load rating (10%)		
Engine	Engine Under speed Shutdown	0RPM - 6000RPM (disabled)	
	Engine Under speed Pre Alarm	0RPM - 6000RPM (disabled)	
	Engine Over speed Pre Alarm	0RPM - 6000RPM (disabled)	
	Engine Over speed Shutdown	0RPM - 6000RPM (disabled)	
	Over speed Overshoot	0% - 10% (0%)	
	Plant Battery Under volt Alarm	0V - 40V (10V)	
	Plant Battery Over volt Alarm	0V - 40V (30V)	
Charge Alternator Failure Alarm	0V - 40V (6V)		
Display	Language	ENGLISH , OTHERS	
AC System	Alternative Frequency	Enable, Disable	
	Alternative Voltage	Enable, Disable	
	AC System	3 Phase 4 wire 1 Phase 2 wire 3 phase 3 wire 2 phase 3 wire L1 & L2 3 phase 4 wire EDISON DELTA 2 phase 3 wire L1 & L3	
	Generator Full Load Current	0A - 8000A (500A)	
	Droop	Enable, Disable	
	Droop %	0% - 5%	Electronic engines only when Droop is enabled
Display	Contrast	<input type="checkbox"/> <input checked="" type="checkbox"/>	
Clock	Date and Time	dd mmm yyyy hh:mm:ss	
Misc.	Run Priority	1-16 (1)	
	Auto Scroll Time	0 - 10s (2.0s)	
CT	Generator CT Primary Rating	0A - 8000A (600A)	Power Cycle After Exit
	Generator CT Secondary Rating	1A, 5A	Power Cycle After Exit
Power	Full kw Rating	0MW-20MW (245kW)	Power Cycle After Exit
	Full kVar Rating	0MVA-20MVA (258kVAr)	Power Cycle After Exit
	Load Ramp Rate	0%-100% (3.0%)	
	Load Level For More Sets	0%-100% (80%)	
	Load Level For Less sets.	0%-100% (70%)	
	Load Parallel Power	0%-100% (172kW)	
	Load Power Factor	0%-100% (1.0pfF 0kVAr 0%)	
	Ramp With P123 Present	Enable Disable	
	Reactive Load Ctl Mode	None, VAr Share , VAr Fixed Export	
	Insufficient Capacity Delay	0 - 30m (1s)	
	Insufficient Capacity Action	None , Shutdown, Electrical Trip, Latched Warning, Unlatched Warning	
	AVR Trim limit Delay	mm:ss (0s)	
	AVR Trim limit action	None /Unlatched warning/Latched warning/Electrical trip/Shutdown	

▲ **NOTE:-** More comprehensive module configuration is possible using the 5xxx series PC configuration software in conjunction with the P810 PC interface. Please contact us for further details.



▲ **NOTE:-** Languages are subject to change as the modules are updated. Please contact us for the list of latest supported languages.



7.12 THE 'RUNNING' CONFIGURATION EDITOR

- The 'running' editor can be entered while the engine is running. All protections remain active if the engine is running while the running editor is entered.
- Press and hold the  button to enter the running editor.

7.12.1 ADJUSTABLE PARAMETERS (RUNNING EDITOR)

- Enter the editor as described above.

- Press the left  or right  buttons to cycle to the section you wish to view/change.

- Press the up  or down  buttons to change the parameter to the required value.

- To save parameters scroll to *save changes and exit* followed by the down  button

- To cancel changes scroll to *Abandon changes and exit* followed by the down  button

Section	Parameter as shown on display	Factory Settings
DISPLAY	Contrast	<input type="checkbox"/> <input checked="" type="checkbox"/>
	Language	English Other
	Gen set run priority	1-16 (1)
	Load Power factor	0-100% (0)
	Load parallel power	0-100% (50)
	Enable commissioning screens	Yes, No
	Override starting alarms	Yes, No
	Voltage adjust (manual mode only engine running breaker open)	0-100 % (0)
	Frequency adjust (manual mode only engine running breaker open)	0-100 % (0)
	Enable mains decoupling test mode (Off mode only)	Yes-No
	Abandon changes and exit	
	Save changes and exit	

8 COMMISSIONING

Before the system is started, it is recommended that the following checks are made:-

- 6.1. The unit has adequate cooling and all the wiring to the module is of a standard and rating compatible with the system.
- 6.2. The unit **DC** supply is fused and connected to the battery and that it is of the correct polarity.
- 6.3. The Emergency Stop input is wired to an external normally closed switch connected to **DC** positive.

 **NOTE:- If Emergency Stop feature is not required link this input to the DC Positive. The module will not operate unless either the Emergency Stop is fitted correctly OR Pin 3 is connected to DC positive.**

- 6.1. To check the start cycle operation take appropriate measures to prevent the engine from starting (disable the operation of the fuel solenoid). After a visual inspection to ensure it is safe to proceed, connect the battery supply. Press the “**MANUAL**” pushbutton, then press the ‘**START**’ pushbutton for a short time. The unit start sequence will commence.
- 6.2. The starter will engage and operate for the pre-set crank period. After the starter motor has attempted to start the engine for the pre-set number of attempts the LCD will display ‘*Shutdown Failed to start*’. Press the **STOP/RESET** pushbutton to reset the unit.
- 6.3. Restore the engine to operational status (reconnect the fuel solenoid), again select “**MANUAL**” and operate the ‘**START**’ pushbutton, this time the engine should start and the starter motor should disengage automatically. If not then check that the engine is fully operational (fuel available, etc.) and that the fuel solenoid is operating. The engine should now run up to operating speed. If not and an alarm is present, check the alarm condition for validity, then check input wiring. The engine should continue to run for an indefinite period. It will be possible at this time to view the engine and alternator parameters - refer to the ‘Description of Controls’ section of this manual.
- 6.4. Select “**AUTO**” on the front panel, the engine will run for the pre-set cooling down period, then stop. The generator should stay in the standby mode. If not check that there is not a signal present on the **Remote Start** input.
- 6.5. Initiate an automatic start by supplying the remote start signal. The start sequence will commence and the engine will run up to operational speed. Once the generator is available a load transfer will take place, the Generator will accept the load. If not, check the wiring to the Generator Contactor Coil (*if used*). Check the Warming timer has timed out.
- 6.6. Remove the remote start signal, the return sequence will start. After the pre-set time period, the load will be removed from the generator. The generator will then run for the pre-set cooling down period, then shutdown into its standby mode.
- 6.7. Further details on synchronising and load sharing can be found in the DSE Guide to Load Share system Design and Commissioning and the DSE Guide to Synchronising and load sharing Part1 and Part2.
- 6.8. If despite repeated checking of the connections between the **7510MK1** and the customer's system, satisfactory operation cannot be achieved, then the customer is requested to contact the factory for further advice on:-

Should you have any queries arising from this manual please contact our Technical Department:

INTERNATIONAL TEL: +44 (0) 1723 890099

INTERNATIONAL FAX: +44 (0) 1723 893303

E-mail: support@deepseapl.com

Web: <http://www.deepseapl.com>

8.1 BYPASSING ALARMS AT STARTUP

When “override starting alarms” is enabled using the Running Editor, it allows alarms to be overridden during the start process by holding the start **I** button. This allows (for instance) the AVR / Governor to be setup without the engine being shutdown on under volts or underfrequency etc. This operation is a ‘one off’ operation, the function is automatically changed back to “No” and must be manually enabled if it is required once more.

The alarms that are overridden during this time are : Undervolts shutdown, Overvolts shutdown, underfrequency shutdown, underspeed shutdown.

The ‘pre-alarms’ remain active to give attention to the operator that an alarm is active, the set will continue to run to allow the operator to adjust the set to nominal speed / voltage.

 **NOTE:- Overfrequency and Overspeed are NOT disabled when this function is activated.**

8.2 COMMISSIONING SCREENS

Commissioning screens are available to both aid the commissioning process and also to give additional information about the synchronising and load sharing process.

These screens can be enabled and disabled in the module’s Running Editor.

8.2.1 SCREEN 1

L-N	0V	kW	0	Average L-N Voltage and total kW
Amps	0A	KVAr	0	Maximum Amps and total kVAr
Pf	0.00	kW	0.0%	Average power factor and % of full load kW
Gov	0.0%	Avr	0.0%	Levels of analogue governor / AVR outputs.

8.2.2 SCREEN 2

Tgt	0.0%	kW	0.0%	Target and actual % of full load kW
Tgt	0.0%	KVAr	0.0%	Target and actual % of full load kVAr
pf	0.0	Ramp	5.0%	Average power factor and ramp position.
Gov	0.0%	Avr	0.0%	Levels of analogue governor / AVR outputs.

9 FAULT FINDING

SYMPTOM	POSSIBLE REMEDY
Unit is inoperative	Check the battery and wiring to the unit. Check the DC supply. Check the DC fuse.
Unit shuts down	Check DC supply voltage is not above 35 Volts or below 9 Volts Check the operating temperature is not above 55 °C. Check the DC fuse.
Unit locks out on Emergency Stop	If an Emergency Stop Switch is not fitted, ensure that a positive is connected to the Emergency Stop input. Check emergency stop switch is functioning correctly. Check Wiring is not open circuit.
Intermittent Magnetic Pick-up sensor fault	Ensure that Magnetic pick-up screen is only connected at one end, if connected at both ends this enables the screen to act as an aerial and will pick up random voltages.
Low oil Pressure fault operates after engine has fired	Check engine oil pressure. Check oil pressure switch/SENSOR and wiring. Check configured polarity (if applicable) is correct (i.e. Normally Open or Normally Closed) or that SENSOR is compatible with the 7510MK1 Module.
High engine temperature fault operates after engine has fired.	Check engine temperature. Check switch/SENSOR and wiring. Check configured polarity (if applicable) is correct (i.e. Normally Open or Normally Closed) or that SENSOR is compatible with the 7520MK1 Module.
Shutdown fault operates	Check relevant switch and wiring of fault indicated on LCD display. Check configuration of input.
Warning fault operates	Check relevant switch and wiring of fault indicated on LCD display. Check configuration of input.
Fail to Start is activated after pre-set number of attempts to start	Check wiring of fuel solenoid. Check fuel. Check battery supply. Check battery supply is present on the Fuel output of the module. Check the speed sensing signal is present on the 7520MK1 inputs. Refer to engine manual.
Continuous starting of generator when in AUTO	Check that there is no signal present on the "Remote Start" input. Check configured polarity is correct.
Generator fails to start on receipt of Remote Start signal or under mains failure conditions.	Check Start Delay timer has timed out. If remote start fault, check signal is on "Remote Start" input. Confirm input is configured to be used as "Remote Start".
Pre-heat inoperative	Check wiring to engine heater plugs. Check battery supply. Check battery supply is present on the Pre-heat output of module. Check pre-heat has been selected in your configuration.
Starter motor inoperative	Check wiring to starter solenoid. Check battery supply. Check battery supply is present on the Starter output of module. Ensure that the Emergency Stop input is at battery positive.
Engine runs but generator will not take load	Check Warm up timer has timed out. Ensure generator load inhibit signal is not present on the module inputs.

 **NOTE:-** The above fault finding is provided as a guide check-list only. As it is possible for the module to be configured to provide a wide range of different features always refer to the source of your module configuration if in doubt.

10 TYPICAL WIRING DIAGRAMS

10.1 3 PHASE 4 WIRE SYSTEM WITH RESTRICTED EARTH FAULT

NOTE:- Earthing the neutral conductor 'before' the neutral CT allows the module to read earth faults 'after' the CT only (Restricted to load / downstream of the CT)
 Earthing the neutral conductor 'after' the neutral CT allows the module to read earth faults 'before' the CT only (Restricted to generator / upstream of the CT)

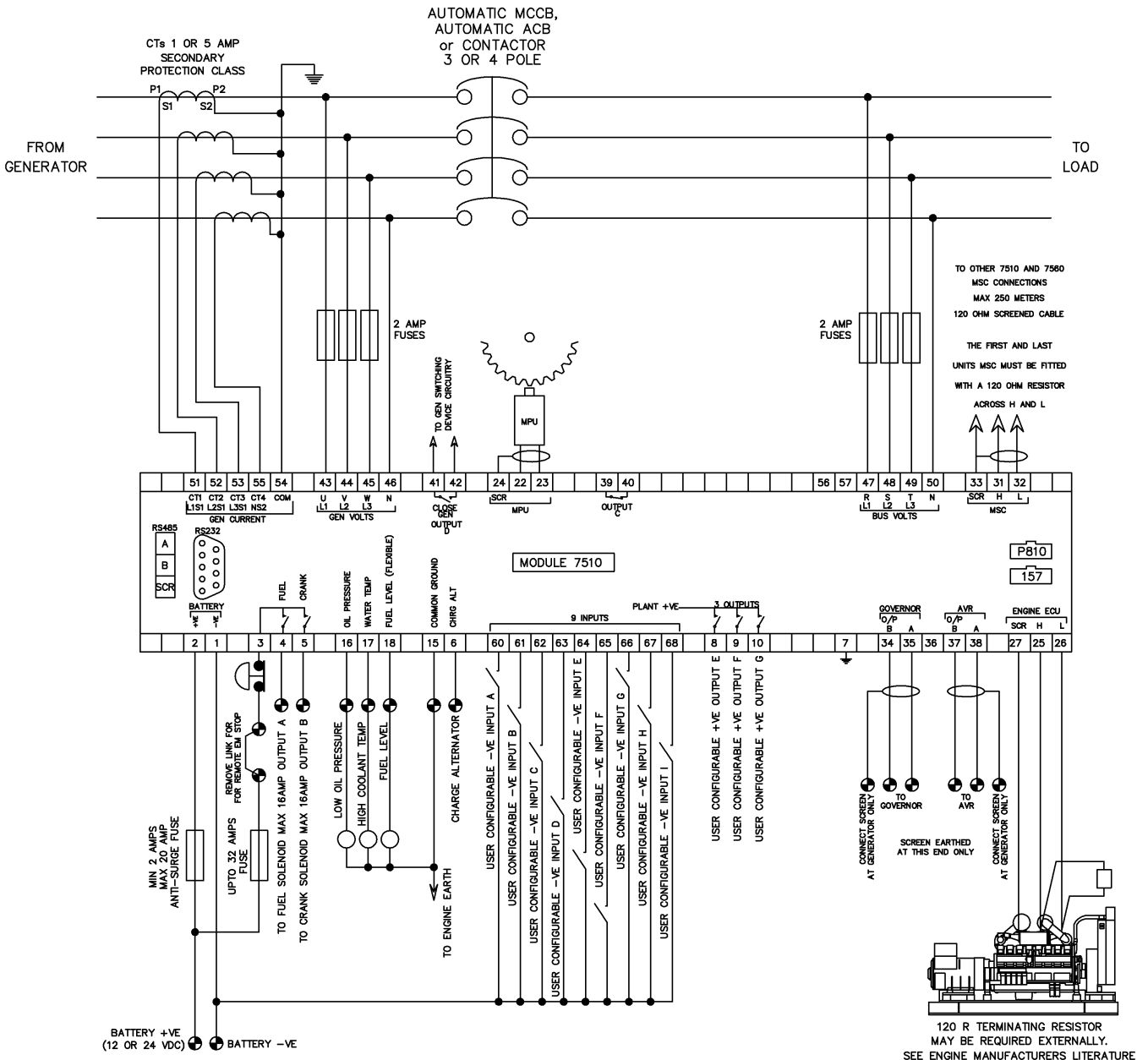

10.2 ALTERNATIVE TOPOLOGIES

The 7000 controller is factory configured to connect to a 3 phase, 4 wire Star connected alternator. This section details connections for alternative AC topologies. Ensure to configure the 7000 series controller to suit the required topology.

NOTE:- Further details of module configuration are contained within the DSE7000 Series configuration software manual (DSE part number 057-078)

10.2.1 3 PHASE, 4 WIRE WITHOUT EARTH FAULT PROTECTION

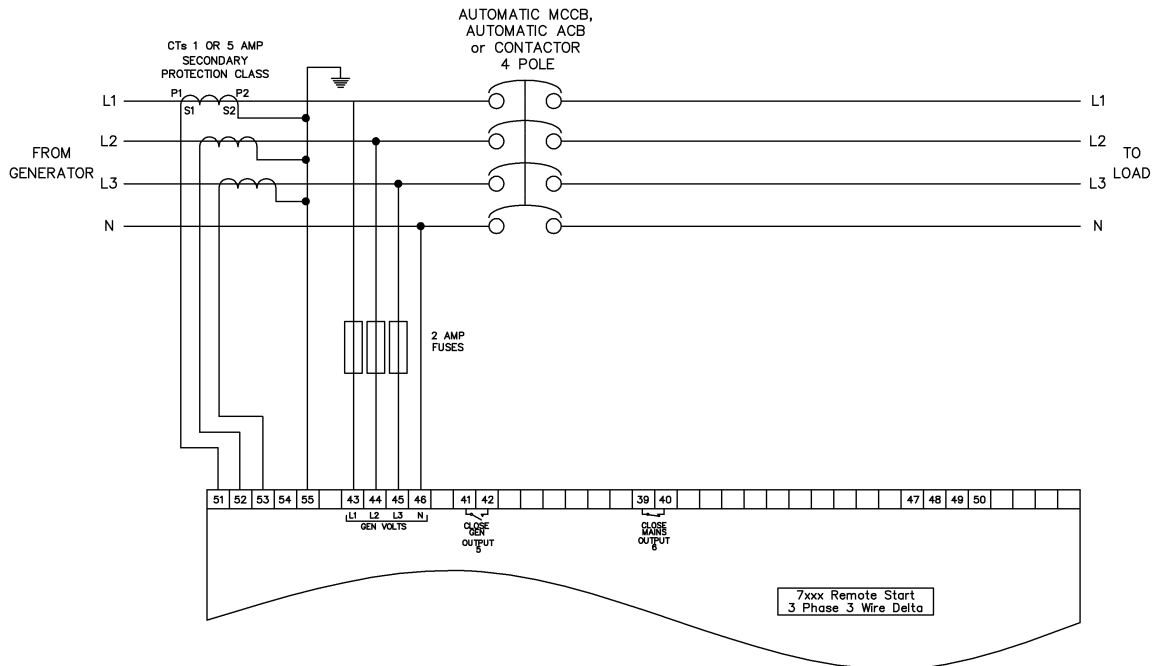

10.2.2 SINGLE PHASE WITH RESTRICTED EARTH FAULT

NOTE:- Earthing the neutral conductor 'before' the neutral CT allows the module to read earth faults 'after' the CT only (Restricted to load / downstream of the CT)
 Earthing the neutral conductor 'after' the neutral CT allows the module to read earth faults 'before' the CT only (Restricted to generator / upstream of the CT)

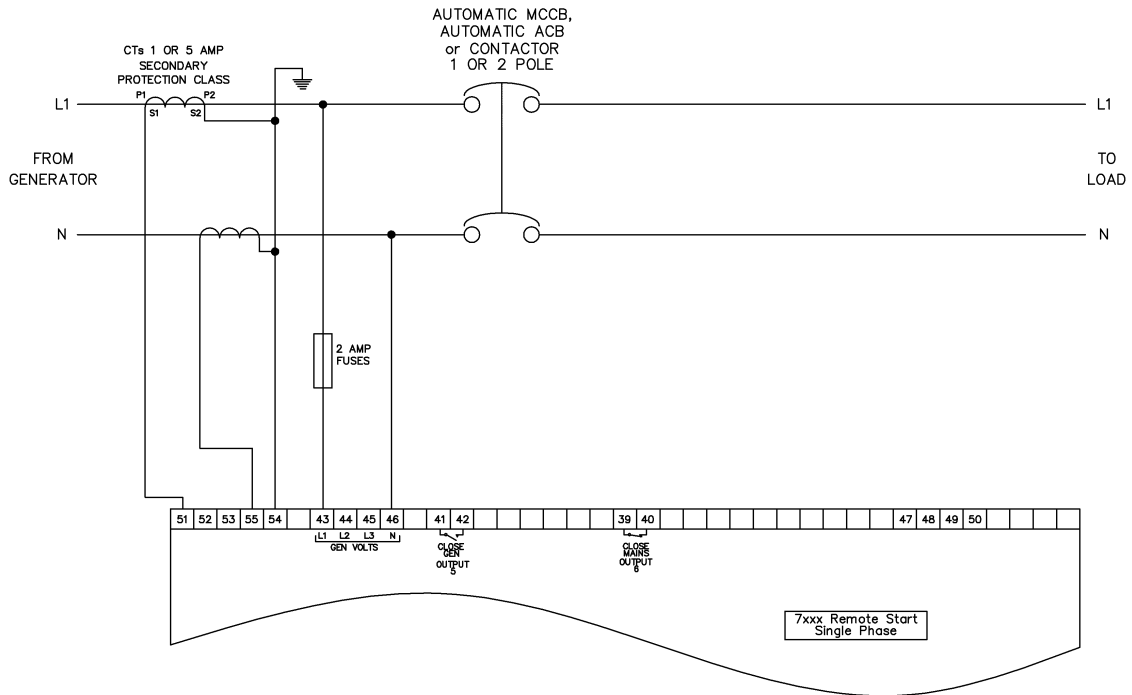

10.2.3 SINGLE PHASE WITHOUT EARTH FAULT

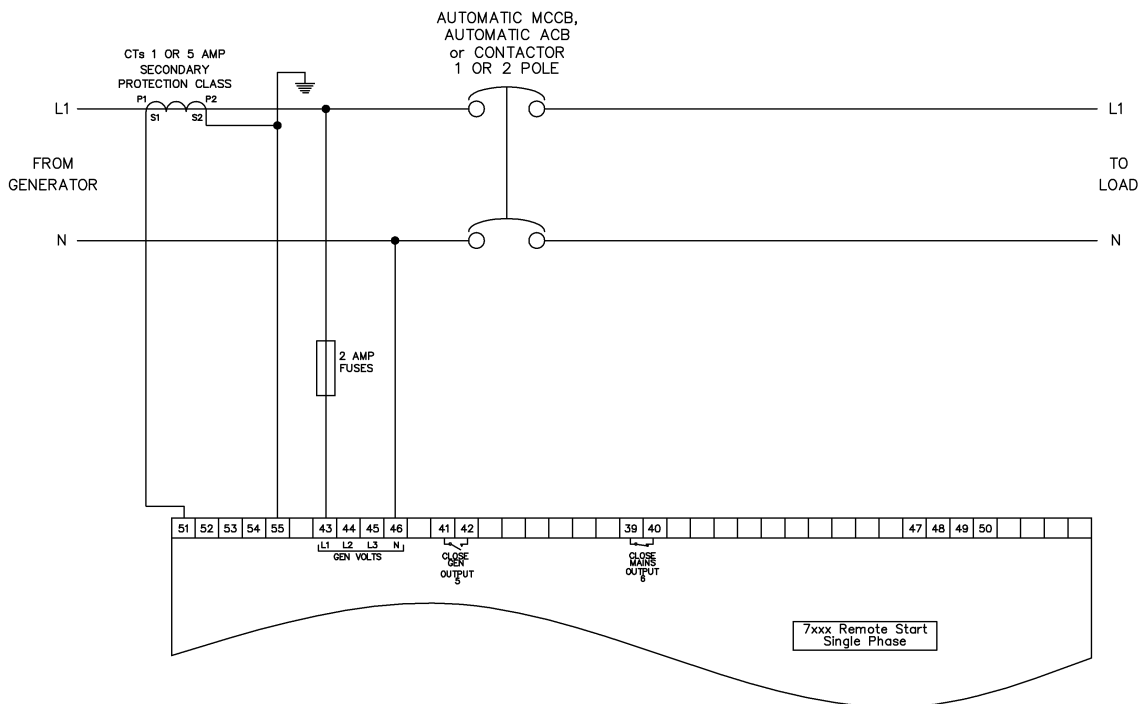

10.2.4 2 PHASE (L1 & L2) 3 WIRE WITH RESTRICTED EARTH FAULT

NOTE:- Earthing the neutral conductor 'before' the neutral CT allows the module to read earth faults 'after' the CT only (Restricted to load / downstream of the CT)
 Earthing the neutral conductor 'after' the neutral CT allows the module to read earth faults 'before' the CT only (Restricted to generator / upstream of the CT)

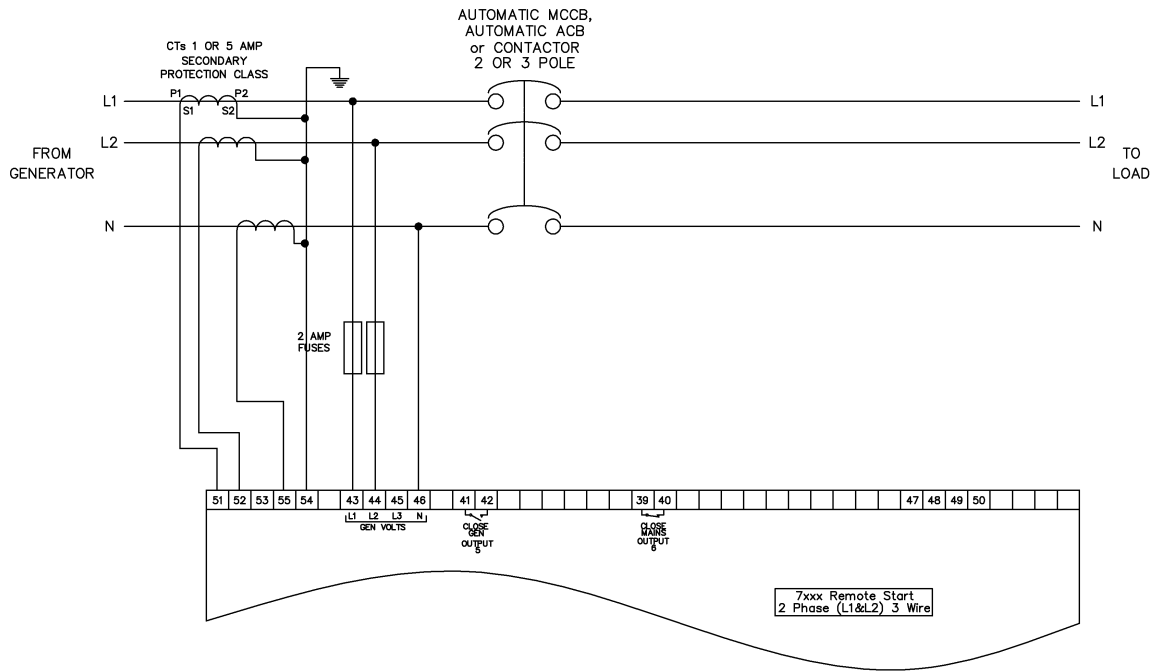

10.2.5 2 PHASE (L1 & L2) 3 WIRE WITHOUT EARTH FAULT

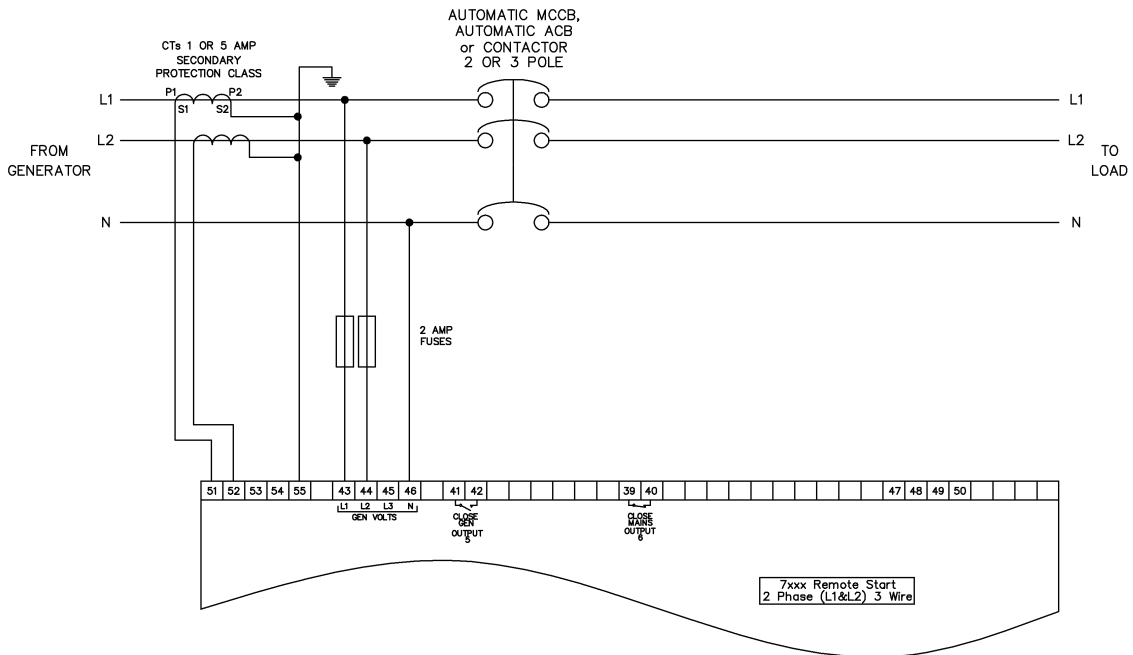

10.2.6 2 PHASE (L1 & L3) 3 WIRE WITH RESTRICTED EARTH FAULT

NOTE:- Earthing the neutral conductor 'before' the neutral CT allows the module to read earth faults 'after' the CT only (Restricted to load / downstream of the CT)
 Earthing the neutral conductor 'after' the neutral CT allows the module to read earth faults 'before' the CT only (Restricted to generator / upstream of the CT)

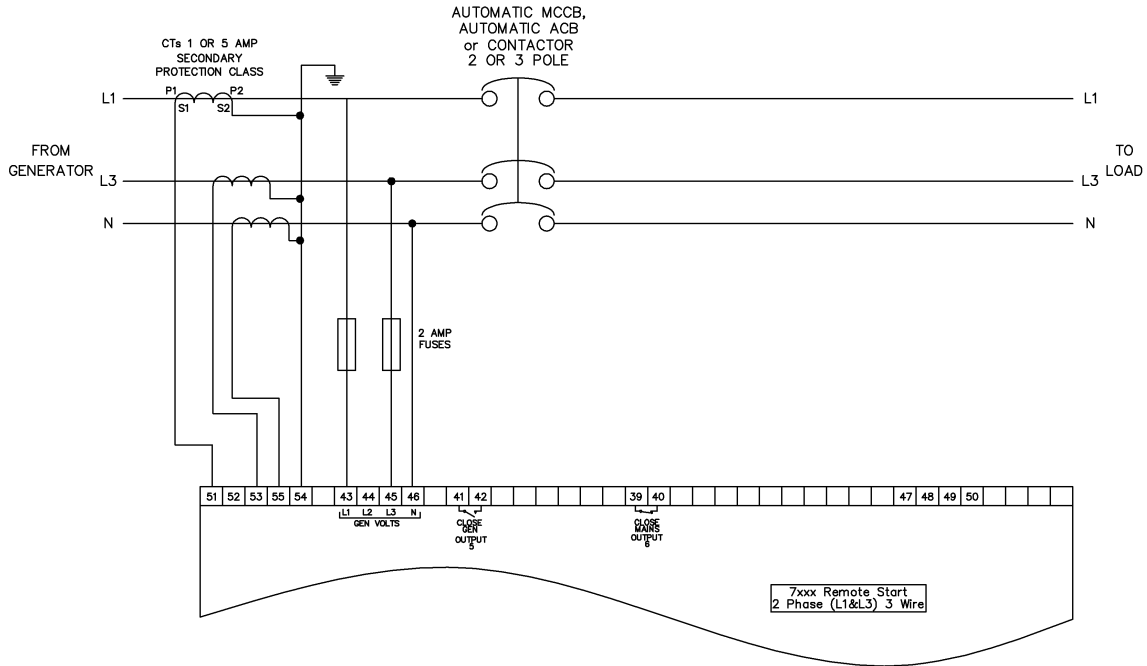

10.2.7 2 PHASE (L1 & L3) 3 WIRE WITHOUT EARTH FAULT MEASURING

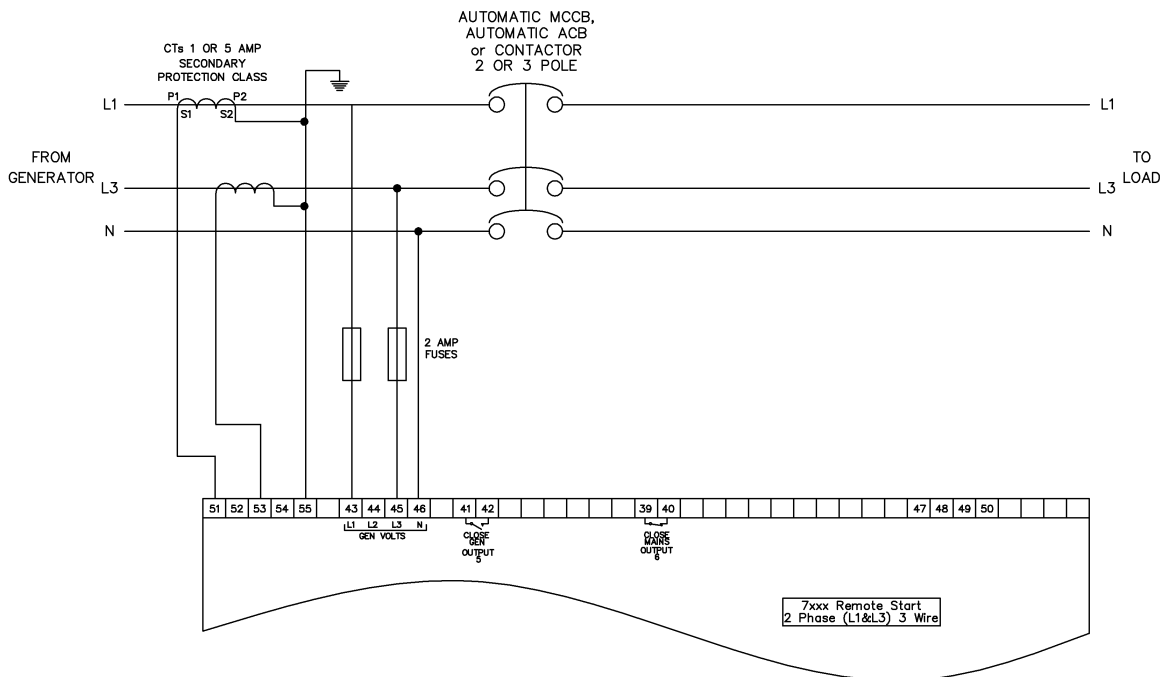

10.2.8 3 PHASE 4 WIRE WITH UNRESTRICTED EARTH FAULT MEASURING

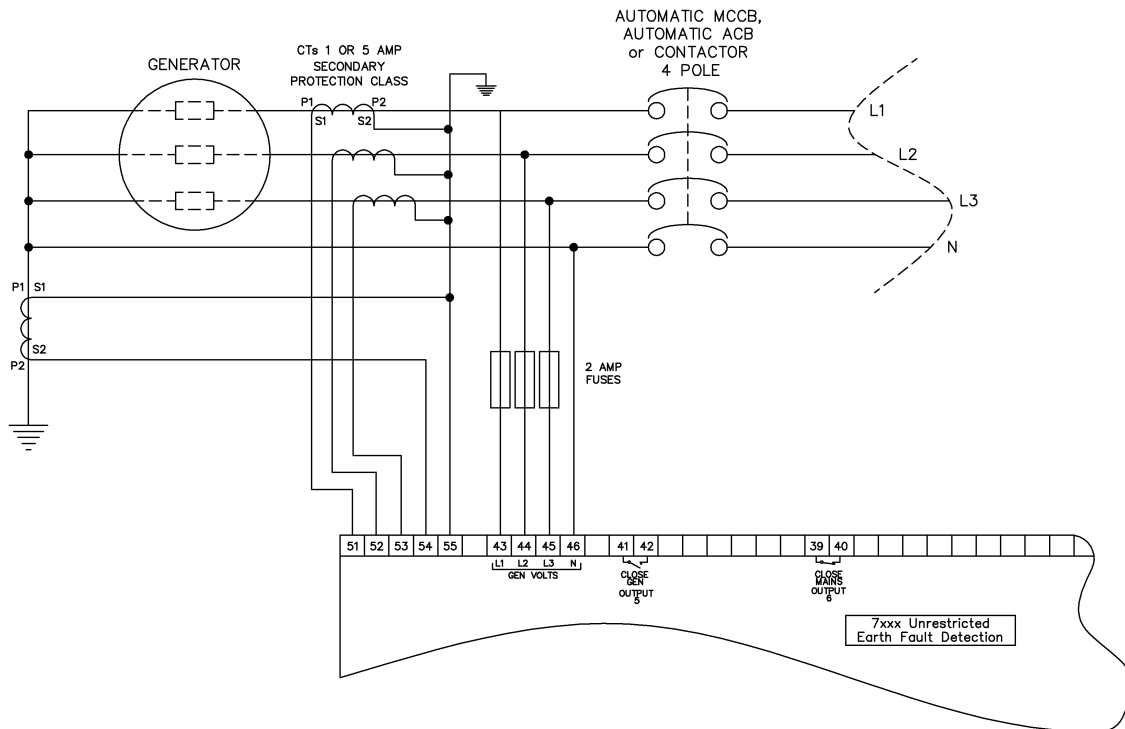

11 SENSOR WIRING RECOMMENDATIONS

11.1 USING EARTH RETURN (SINGLE WIRE) SENSORS.

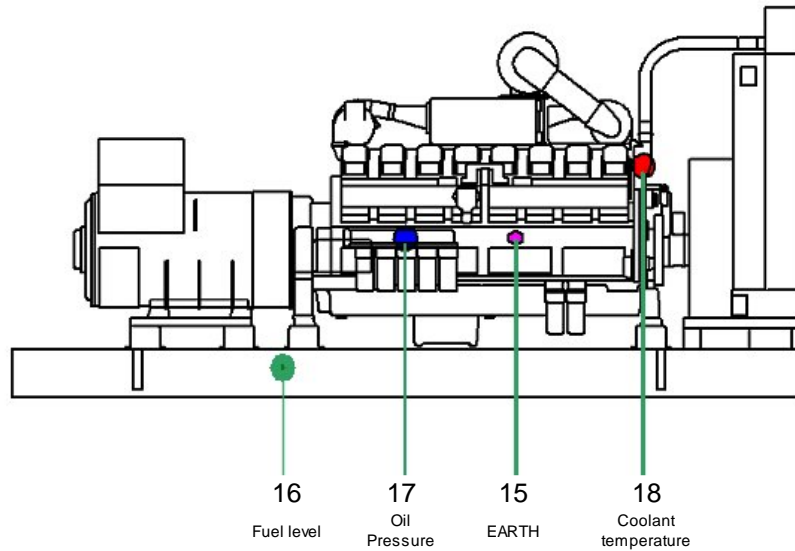

NOTE:- It is important that terminal 15 (SENSOR common) is soundly connected to an earth point on the ENGINE BLOCK, not within the control panel and must be a sound electrical connection to the SENSOR bodies. If you use PTFE insulating tape on the SENSOR thread when using earth return SENSORS, ensure you do not insulate the entire thread as this will prevent the SENSOR body from being earthed via the engine block.

11.2 USING INSULATED RETURN (TWO WIRE) SENSORS.

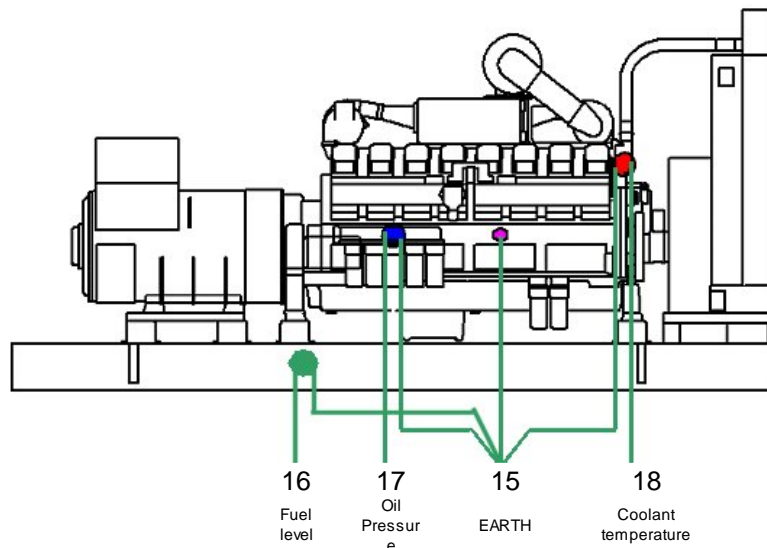

NOTE:- . It is important that terminal 15 (SENSOR common) is soundly connected to an earth point on the ENGINE BLOCK, not within the control panel .

12 APPENDIX

12.1 ACCESSORIES

12.1.1 OUTPUT EXPANSION

There are several methods of output expansion available for the 75xxMK1 range of modules: -

RELAY OUTPUT EXPANSION (157)

An expansion module is available, which connects to the configuration socket, and enables the 75xxMK1 to use eight additional relays, providing Volt-free contacts for customer connection. A maximum of two of these units can be used give 16 independent volt-free contacts.

The 157's need to be identified as module 'A' and module 'B'

Refer to technical data sheet on the 157 relay module for further details.

LED OUTPUT EXPANSION (548)

An expansion module is available, which connects to the configuration socket, and enables the 75xxMK1 to use the eight additional LED's on the 548 module, providing remote LED's indication. A maximum of two of these units can be used give 16 independent remote LED's.

The 548's need to be identified as module 'A' and module 'B'

Refer to technical data sheet on the 548 LED modules for further details.

It is possible to use a mix of 157 and 548 modules to give both relay and LED expansion if required.

12.1.2 INPUT EXPANSION (P130/P540/P541)

It is possible to increase the number of monitored inputs available by utilising either:

- DSE P130 input expansion.
- 540 / 541 Protection Expansion/Annunciator.

Please refer to the relevant product documentation for further details.

12.2 COMMUNICATIONS OPTION

12.2.1 DESCRIPTION

The 5xxx series configuration software allows the 7510MK1 controller to communicate with a PC. The computer can be connected to the module either directly, via a modem (RS232)* or via an RS485 link**.

The operator is then able to remotely control the module, starting or stopping the generator, selecting operating modes, etc. The various operating parameters (such as output volts, oil pressure, etc.) on the remote generator can also be viewed.

The information contained in this manual should be read in conjunction with the appropriate module documentation. This manual only details the operation of the communications software and how it should be used. The operation of the module is detailed in its own relevant manual.

NOTE: - *If modem communications is a requirement, then it is important to order the correct 7510MK1 module with the RS232 communications board fitted. This provides a 9-way D-type connector suitable for connection to the modem. Please refer to the *comms* section of this manual for details of how the system should be configured.

**If RS485 communications is required, then it is important to order the correct 7510MK1 module with the RS485 communications board fitted. This provides a 3-way terminal block for connection of the RS485 link.

12.2.2 CONTROLLER TO PC (DIRECT) CONNECTION

To connect a 7510MK1 to a modem the following items are required: -

- 7510MK1 Module
- 5xxx series configuration software (Supplied on DSE software CD).
- P810 interface (USB or RS232 as required)

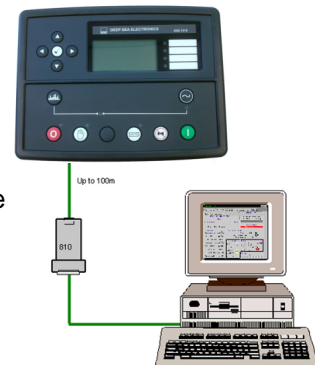

12.2.3 CONTROLLER TO ETHERNET CONNECTION

To connect a 7510MK1 to the Ethernet the following items are required: -

- 7510MK1 Module (1 to 6 DSE7510 controllers are supported and up to 2 DSE7560 controllers)
- 75xx series configuration software
- DSE850 multiset Ethernet module

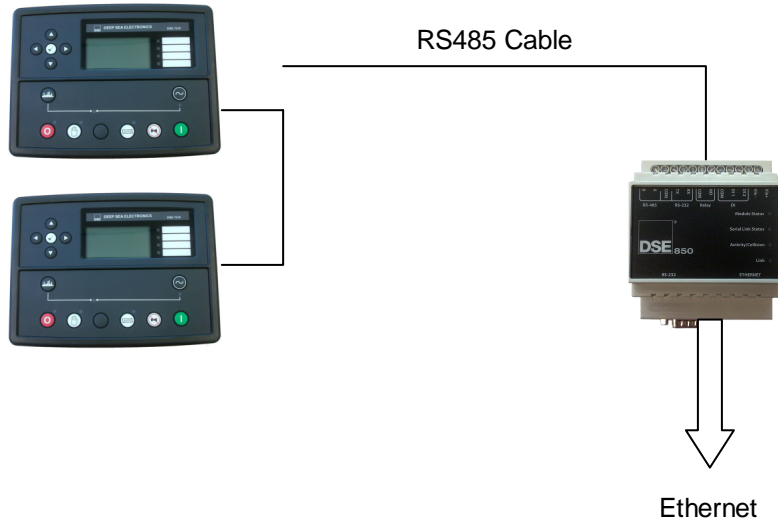

Sample screenshot of 4 x DSE7510 and 1 x DSE7560 controllers



12.2.4 CONTROLLER TO MODEM CONNECTION

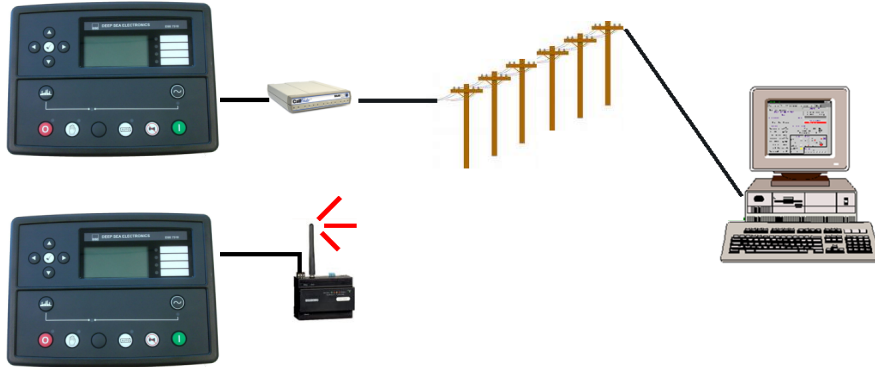

To connect a 7510MK1 to a modem the following items are required: -

- 7510MK1 Module with RS232 Communications Interface enabled
- Compatible RS232 Modem (PSTN or GSM)
- Suitable connection leads
- Power supply for the modem
- 5xxx series configuration software (Supplied on DSE software CD).
- Access to a PSTN Line or GSM network.

CAUTION! - The modem must be powered from a suitably stabilised supply, preferably supplied with the modem. Failure to ensure continuity of supply will result in communication difficulties at such times as Mains failure or during cranking. An uninterruptible power supply arrangement is recommended (AC or DC depending on modem power requirement).

12.2.5 RS485 LINK TO CONTROLLER

The RS485 enabled 7510MK1 modules are able to communicate with a PC or other RS485 enabled device over a standard RS485 connection. Typical uses of RS485 are:

- Direct connection to a remote PC running the Link5000 software. RS485 is capable of communication over a distance of 1.2km where suitable 120Ω RS485 cable is installed.
- Connection to a building management to allow mains, generator and engine parameters/alarm conditions to be displayed along with information from other devices (air conditioning, fire alarm system etc).

Typical connections of RS485 PC system (master) to RS485 DSE controller (slave)

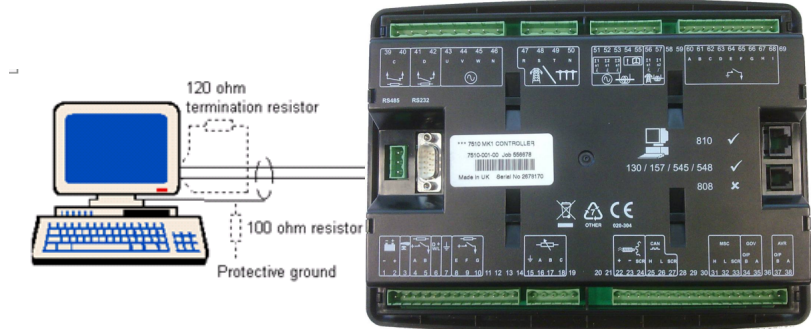

NOTE: - The RS485 system will comprise of one MODBUS master (typically a PC) and up to 31 MODBUS slaves. The 7510MK1 modules are always MODBUS slave devices. To ensure correct operation a suitable 120Ω terminal resistor must be fitted to each end of the RS485 connection bus.

Caution! - The A and B lines of the 485 network should be terminated at each end with a 120Ω resistor.

Some RS485 devices (PC cards in particular) are already fitted with a terminating resistor. However if they are not installed as an 'end of line' device then such terminating resistors must be removed. Other RS485 devices may be fitted with a 'switchable' resistor, again this must be switched out if the device is not installed as an 'end of line' device.

TYPICAL BUILDING MANAGEMENT SCHEME USING RS485 MONITORING

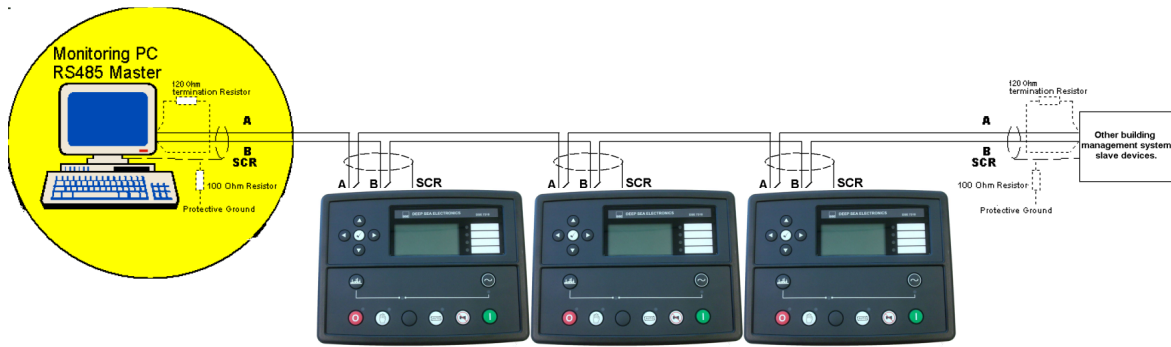

CAUTION! -. RS485 cabling must be 120Ω impedance cable, specified for use with RS485. 120Ω terminating resistors must be fitted to the first and last devices on the bus. Some PC RS485 cards are already fitted with this resistor, and in this case should not be fitted externally. If in doubt, consult the supplier of your PC RS485 card. If the 7510MK1 controller is the 'last' device on the bus, then it's RS485 connection must be suitably terminated with a 120Ω resistor as detailed in the specification laid out in the RS485 standard.

Recommended cable BELDEN 9841 120Ω RS485 cable.
DSE part number 016-030.

NOTE: - The RS485 output uses 'MODBUS' protocol. It is possible to use third party software to monitor and control the 7510MK1 module via this protocol. Please refer to Deep Sea Electronics Plc for details.

12.2.6 MODBUS

The RS485 output uses Modbus communications protocol. This uses a master-slave technique to communicate. Only the Master can initiate a packet transaction, called a 'query'. When appropriate the slave (7510MK1 Module) responds to the query and provides the information requested by the master.

All supported data can be read and written as specified in the register table (documentation is available from Deep Sea Electronics Plc.).

When the 7510MK1 Module receives a query it will respond by either supplying the requested register data or performing the requested action. A slave device (the 7510MK1 module) will never initiate communications on the Modbus™ link. The 7510MK1 can only be configured as a slave device. The Master can only query individual slaves. Refer to the Modbus™ protocol document for more details.

Refer to the Link5000plus Manual for further details on communications expansion.

NOTE:- 7600MK1 controller only available with RS485 communications.

12.3 ENCLOSURE CLASSIFICATIONS

IP CLASSIFICATIONS

BS EN 60529 Degrees of protection provided by enclosures

First Digit	Second digit
Protection against contact and ingress of solid objects 0 No protection	Protection against ingress of water 0 No protection
1 Protected against ingress solid objects with a diameter of more than 50 mm. No protection against deliberate access, e.g. with a hand, but large surfaces of the body are prevented from approach.	1 Protection against dripping water falling vertically. No harmful effect must be produced (vertically falling drops).
2 Protected against penetration by solid objects with a diameter of more than 12 mm. Fingers or similar objects prevented from approach.	2 Protection against dripping water falling vertically. There must be no harmful effect when the equipment (enclosure) is tilted at an angle up to 15° from its normal position (drops falling at an angle).
3 Protected against ingress of solid objects with a diameter of more than 2.5 mm. Tools, wires etc. with a thickness of more than 2.5 mm are prevented from approach.	3 Protection against water falling at any angle up to 60° from the vertical. There must be no harmful effect (spray water).
4 Protected against ingress of solid objects with a diameter of more than 1 mm. Tools, wires etc. with a thickness of more than 1 mm are prevented from approach.	4 Protection against water splashed against the equipment (enclosure) from any direction. There must be no harmful effect (splashing water).
5 Protected against harmful dust deposits. Ingress of dust is not totally prevented but the dust must not enter in sufficient quantity to interface with satisfactory operation of the equipment. Complete protection against contact.	5 Protection against water projected from a nozzle against the equipment (enclosure) from any direction. There must be no harmful effect (water jet).
6 Protection against ingress of dust (dust tight). Complete protection against contact.	6 Protection against heavy seas or powerful water jets. Water must not enter the equipment (enclosure) in harmful quantities (splashing over).

NEMA CLASSIFICATIONS

 **NOTE: - There is no direct equivalence between IP / NEMA ratings. IP figures shown are approximate only.**

1 IP30	Provides a degree of protection against contact with the enclosure equipment and against a limited amount of falling dirt.
2 IP31	Provides a degree of protection against limited amounts of falling water and dirt.
3 IP64	Provides a degree of protection against windblown dust, rain and sleet; undamaged by the formation of ice on the enclosure.
3R IP32	Provides a degree of protection against rain and sleet; undamaged by the formation of ice on the enclosure.
4 (X) IP66	Provides a degree of protection against splashing water, windblown dust and rain, hose directed water; undamaged by the formation of ice on the enclosure. (Resist corrosion).
12/12K IP65	Provides a degree of protection against dust, falling dirt and dripping non corrosive liquids.
13 IP65	Provides a degree of protection against dust and spraying of water, oil and non corrosive coolants.

12.4 IEEE C37.2 STANDARD ELECTRICAL POWER SYSTEM DEVICE FUNCTION NUMBERS

The DSE 7510MK1 contains many protection devices and functions, which are listed in detail in the following sections.

Functions and protections provided corresponding to IEEE C37.2 (1996) system device numbers are listed below.

Overall the 7510MK1 is designated as 11 - Multifunction device and includes the following protections and functions:

Device	Description
2	time delay starting or closing relay
3	checking or interlocking relay
5	stopping device
12	overspeed device
14	underspeed device
15	speed or frequency matching device
18	accelerating or decelerating device
25	synchronizing or synchronism-check relay
27	undervoltage relay
30	annunciator relay
31	separate excitation device
32	directional power relay
46	reverse-phase or phase-balance current relay
48	incomplete sequence relay
50	instantaneous overcurrent relay
51	ac time overcurrent relay

Device	Description
52 ac circuit breaker	A device that is used to close and interrupt an ac power circuit under normal conditions or to interrupt this circuit under fault or emergency conditions.
54 turning gear engaging device	A device electrically operated, controlled, or monitored that functions to cause the turning gear to engage (or disengage) the machine shaft.
55 power factor relay	A device that operates when the power factor in an ac circuit rises above or falls below a predetermined value.
59 overvoltage relay	A device that operates when its input voltage exceeds a predetermined value.
62 time-delay stopping or opening relay	A device that imposes a time delay in conjunction with the device that initiates the shutdown, stopping, or opening operation in an automatic sequence or protective relay system.
63 pressure switch	A device that operates at a given pressure value or at a given rate of change of pressure.
69 permissive control device	A device with two-positions that in one position permits the closing of a circuit breaker, or the placing of a piece of equipment into operation, and in the other position, prevents the circuit breaker or the equipment from being operated.
71 level switch	A device that operates at a given level value, or on a given rate of change of level.
74 alarm relay	A device other than an annunciator, as covered under device function 30, that is used to operate, or that operates in connection with, a visual or audible alarm.
78 phase-angle measuring relay	A device that functions at a predetermined phase angle between two voltages, between two currents, or between voltage and current.
81 frequency relay	A device that responds to the frequency of an electrical quantity, operating when the frequency or rate of change of frequency exceeds or is less than a predetermined value.
83 automatic selective control or transfer relay	A device that operates to select automatically between certain sources or conditions in equipment or that performs a transfer operation automatically.
86 lockout relay	A device that trips and maintains the associated equipment or devices inoperative until it is reset by an operator, either locally or remotely.
90 regulating device	A device that functions to regulate a quantity or quantities, such as voltage, current, power, speed, frequency, temperature, and load, at a certain value or between certain (generally close) limits for machines, tie lines, or other apparatus.

12.5 SYNCHRONISING NOTES

Optionally, the 7510MK1 controller can be configured to forward synchronise, volts match and parallel with the mains supply. This facility can be used to supply a fixed amount of power to the load and/or mains supply or share load with other 7510MK1, 5510 or 550 enabled generator systems.

12.5.1 CHECK SYNC

(If enabled)

The module will control the operation of the load-switching device to allow parallel operation with the mains / bus supply only when the two supplies are in synchronism.

12.5.2 AUTO SYNC

(If enabled)

The module provides control signals to the Engine Governor and the Alternator AVR to control the speed and voltage output from the generating set.

Refer to the 5xxx software manual for further details.

12.5.3 LOAD CONTROL

(If enabled)

The module features all the functions associated with the Check sync and auto sync features and in addition, it provides control signals to the Engine Governor and the Alternator AVR while in parallel with the mains (utility) or generator bus.

These functions can be used to provide peak shaving and load sharing with other 7510MK1 enabled generating set systems.

Refer to the 5xxx software manual for further details.

12.5.4 TYPICAL LOAD SHARING SYSTEM

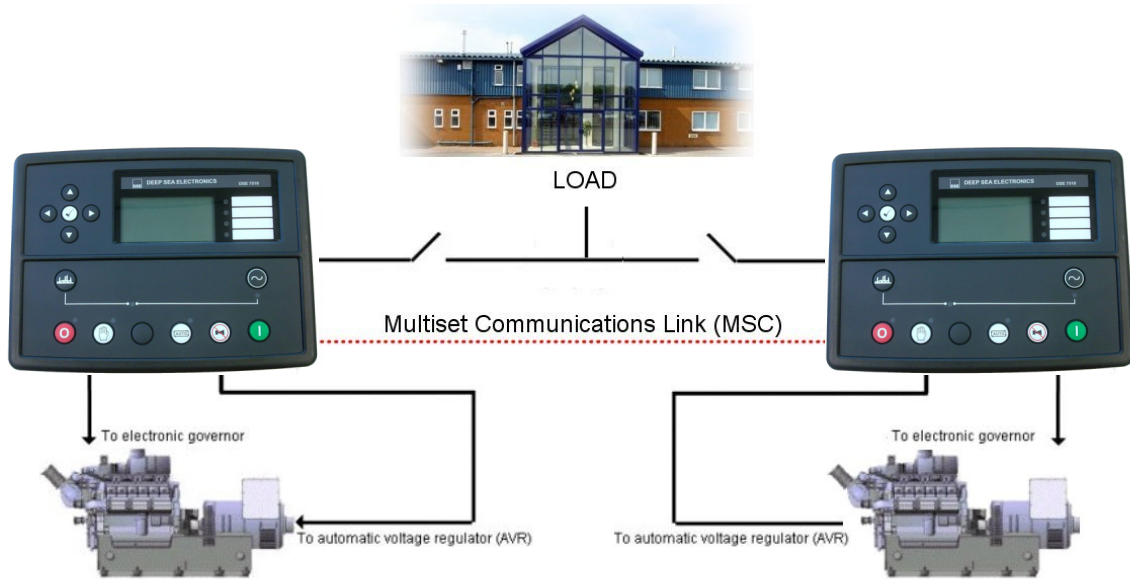

NOTE:- Up to 16 sets can be connected in parallel in this way, sharing kW load (and kVAr load if required) utilising the multi-set communications link (MSC).

12.5.5 TYPICAL PEAK SHAVING SYSTEM

(Generator provides a fixed amount of power)

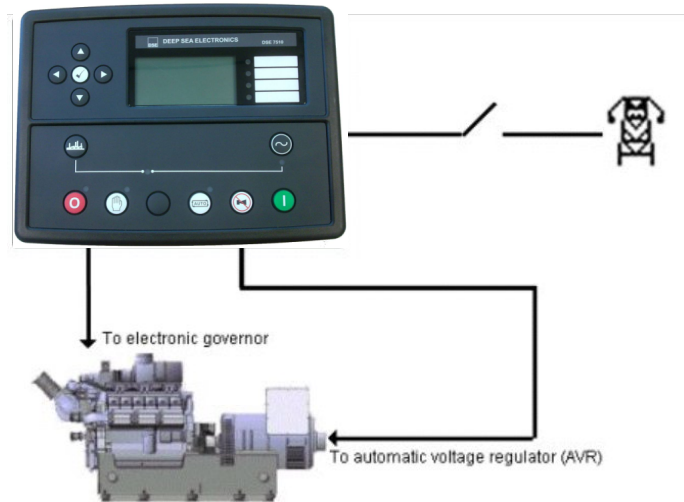

For further details on this subject you are referred to the Deep Sea Electronics Guide to Synchronising and Load Sharing. This document includes diagrams to show connections to many of the most common electronic governors and interfaces.

Utilising the 7600MK1 mains controller, the 7510MK1 can be incorporated into a true peak lopping system with multiple generator sets and multiple mains supplies and loads. Please consult Deep Sea Electronics for further information.