

ESG2005 Series Electronic Governor Instruction

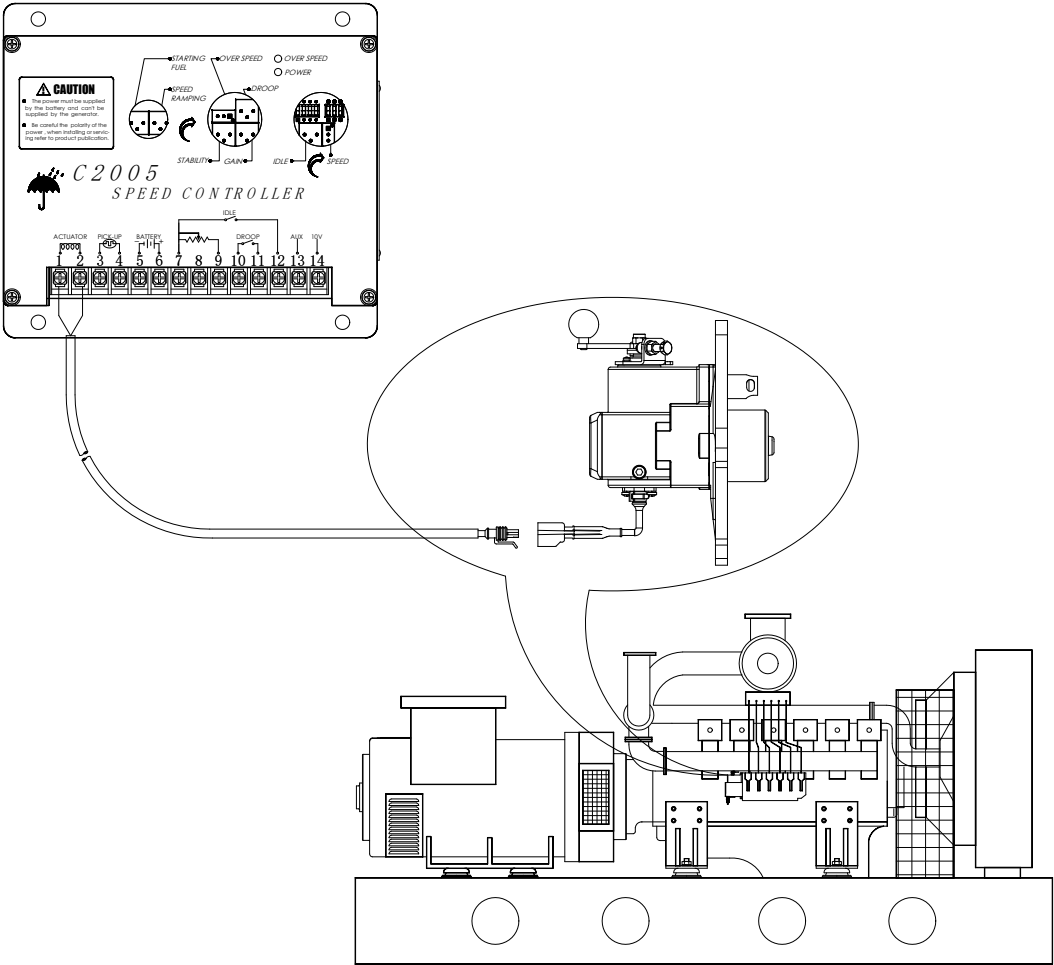

CATALOGUE

1	Principle	1
2	System Composing	2
2.1	Speed Controller	2
2.2	Electromagnetic Actuator	5
2.3	Speed Pick-up	13
3	Installing and Debugging	14
3.1	Installing Of The Electronic Governor	14
3.2	Connection Diagram	14
3.3	Debugging before starting engine	15
3.4	Parameter adjustment	16
3.5	Adjusting the DROOP	21
3.6	Auxiliary input	22
4	System Troubleshooting	23
4.1	Fault judgment of the electronic governor	23
4.2	Insufficient Magnetic Speed Sensor Signal	24
4.3	Electromagnetic Compatibility (EMC)	24

Foreword

This manual mainly introduced the working principle of the electronic speed control system, system composition, Regulation, operation, maintenance and simple troubleshooting method, suitable for a certain understanding, to the engine and the electronic governor routine installation, use and repair personnel. Recommend the product specification in the workplace, and strictly follow the method given here to operate.

Caution

- Speed sensor to the electronic control system shall not be shared with other systems, or they may cause serious consequences.
- You can't rely on the electronic speed control system to prevent engine overspeed, and overspeed protection device installed independently, effectively in the engine system.
- Before starting the engine should confirm the fuel injection pump rod in oil cut-off position, push and pull the fuel rack should be flexible and no jam.

1 The Principle Of The Electronic Governor System

Electronic governor, with its simple structure, high reliability, convenient operation, easy function extension and high cost performance, applies to all kinds of diesel generating sets, vehicles and marine diesel engines.

Its normal type is all-electronic single pulse speed and close loop position structure, provided with functions of non-corresponding or corresponding control, speed and rated speed during running maximum fuel supply control, emergency stop and etc.

It is also capable of adding other control functions according to the customer's particular requirements.

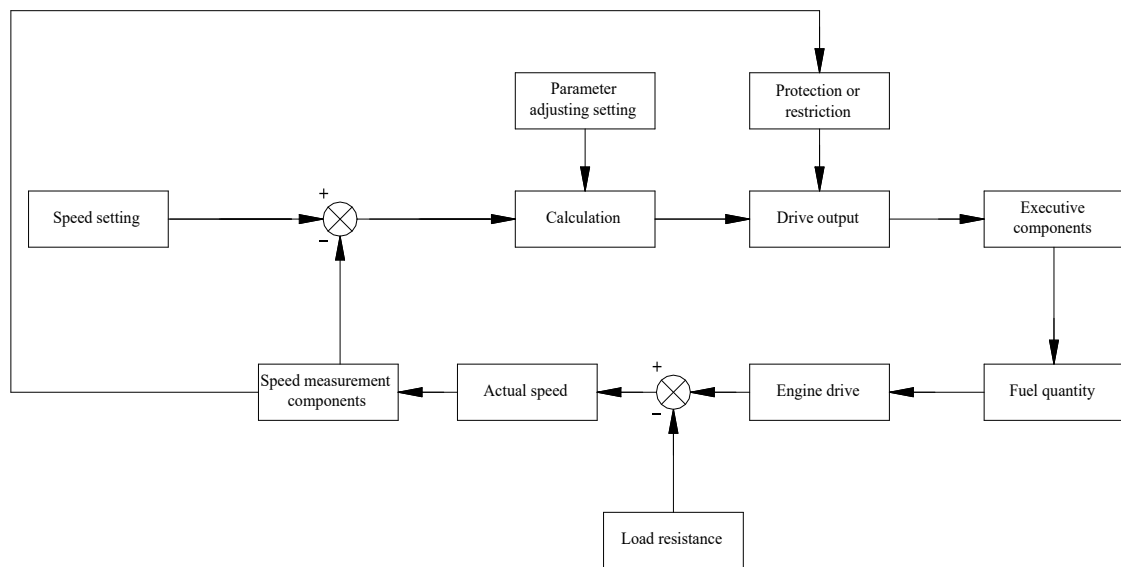

Figure 1.1 Electronic governor system

The closed-loop control mode of the electronic governor can make a quick and accurate response to the instantaneous load change, which can control the engine speed to the stable trend. Manually adjust the potentiometers such as GAIN, STABILITY and DROOP to meet the requirements of different engines on the transient adjustable rate, time stability and steady-state rate.

2 The Structure Of The Electronic Governor System

2.1 Speed Control Unit

2.1.1 The basic electronic characteristics

- SUPPLY VOLTAGE : DC 24V (Scope 18V~32V) or DC12V (Scope9V~16V)
- SUPPLY CONSUMPTION : < 0.2A (static state)
- SPEED FLUCTUATION RATIO : $\leq \pm 0.25\%$
- STEADY STATE SPEED DROOP : 0~5% Adjustable
- AMBIENT TEMP. : -40°C ~ +85°C
- RELATIVE HUMIDITY : <95%

2.1.2 Basic Performance Of C2005 controller

- Adjustable starting fuel: adjusting the status of the smoke exhaust when the engine starts;
- Speed control and fine adjustment: adopting the single closed-loop method to realize accurate speed adjustment and remote control;
- Raising speed time adjustable: can adjust engine from idle to the rated status;
- Overspeed protection: Can set the overspeed limit value, cut off the actuator power supply, stop the engine;
- High and low speed conversion: can convert between idle status and rated status;
- Droop adjustable: can adjust the speed range;
- Parallel machine function: can realize parallel machine function by manual or automatic way;
- The whole speed adjusting: can adjust speed in a continuous and smooth condition within a certain range;
- Automatic shutdown protection: when the speed signal disappears or the controller is power off, the engine will shutdown automatically;

For more information about the basic performance, please see the following chapter about the parameter setting instruction. The function of whole course speed governing may require the different external connection accessories according to user's different requirement of speed governing range. If you need this function please contact us.

2.1.3 The outline overall and installing dimension of controller C2005

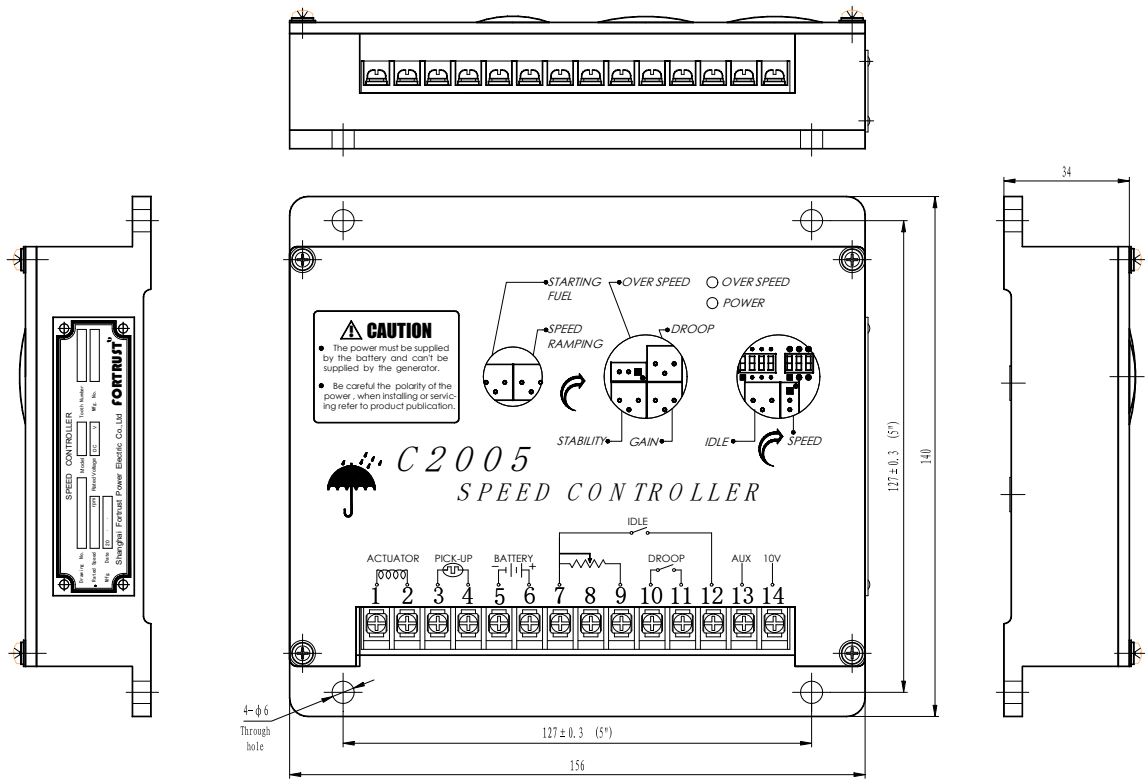

Figure 2.1 The outline overall and installing dimension of controller C2005

2.1.4 The wiring diagram of speed controller C2005

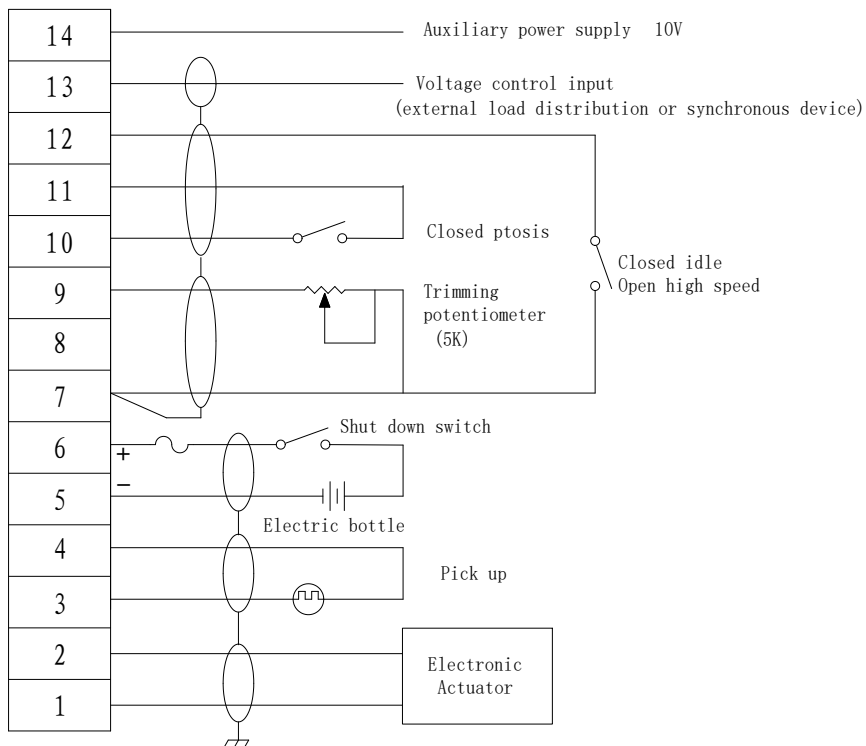
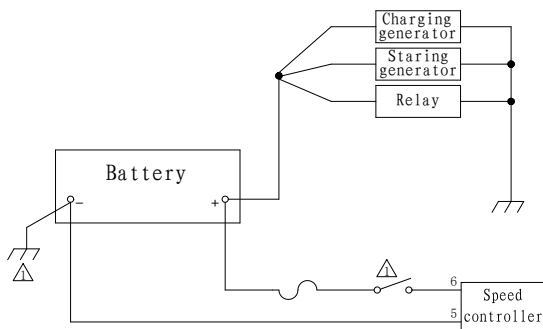

Figure 2.2 The wiring diagram of speed controller C2005

2.1.5 The definition and requirement of Connection Terminal:

● Terminal 1 and 2 is use for connecting the actuator, terminal 5 and 6 is use for connecting the battery, the cable section should be 1.3 mm² or more to decrease the voltage drop, so more long more bigger. For avoiding the accident, a 15 A fuse is necessary on the cable that is from the battery positive to the power positive of the speed controller (terminal 6);The cable of the speed controller should be connected directly and separately from the battery positive and negative, please don't connect to other terminal, for the correct way see below:



☑ The correct wiring diagram

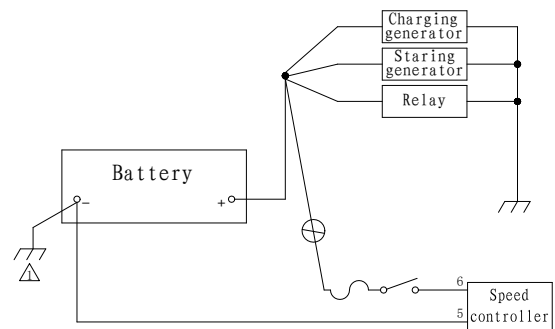

☒ The wrong wiring diagram

● Terminal 3 and 4 is use for connecting the speed sensor, the cable should be the braided shielded net cable and connect to the point by 360° as figure 3.1 indicated, but it can't be connected to others of the engine ,otherwise it may have the interference signal input to the speed controller and result in the unpredictable consequence;

● The remote potentiometer connects to Terminal 7 and 9. (FREQ TRIM), and can be extended cable remote control (the longest cable up to 5M), If the length of cable exceeds the required limited value, you must use the braid shielding network cable for connection, the shielding net ring shall be 360-degree ring receiving terminal 7, If it resistance is 5KΩ, speed adjusting range is 2400HZ.

● Speed droop connects to Terminal 10 and 11. When the Terminal 10 and 11 is off, speed droop is 0; When the Terminal 10 and 11 is closed, speed droop range is 0-5%;

● Rated and idle speed switch connects to Terminal 7 and 12, when the idle running state is closed, Up to the rated speed of the time after the break open up to the rated speed.

● T Terminal 13(AUX) can be used as external voltage control device setting, As a sensitive input terminal, it is recommended to use the shielding cables to connect with various parts to prevent the external signal interference; this terminal can be directly connected to the synchronous controller and load distributor produced by Fortrust; There is no need to connect in unit operation; .

● Terminal 14 output +10 volt regulated supply.

2.2 The Electromagnetic Actuator

The speed controller as this manual mentioned can used with all of the single close-loop actuator that produced by Fortrust, customer choose the actuator and middle plate flexibly according to the model number of the pump, and you also can ask for Fortrust People provide a best solution to you after testing in the site. The specification listed in the electromagnetic actuator is according to your product with asked to list, if need to query Fortrust execution of the production of the electromagnetic device types and details can be linked through the page table and contact us . ifferent actuator with different stability, if you find the problem about that please contact us, we will provide the professional solution to you.

2.2.1 A800C-W electromagnetic actuator

- WORKING VOLTAGE: DC24V
- WORKING TORQUE: 0.8 N.m
- WORKING STROKE: 17mm

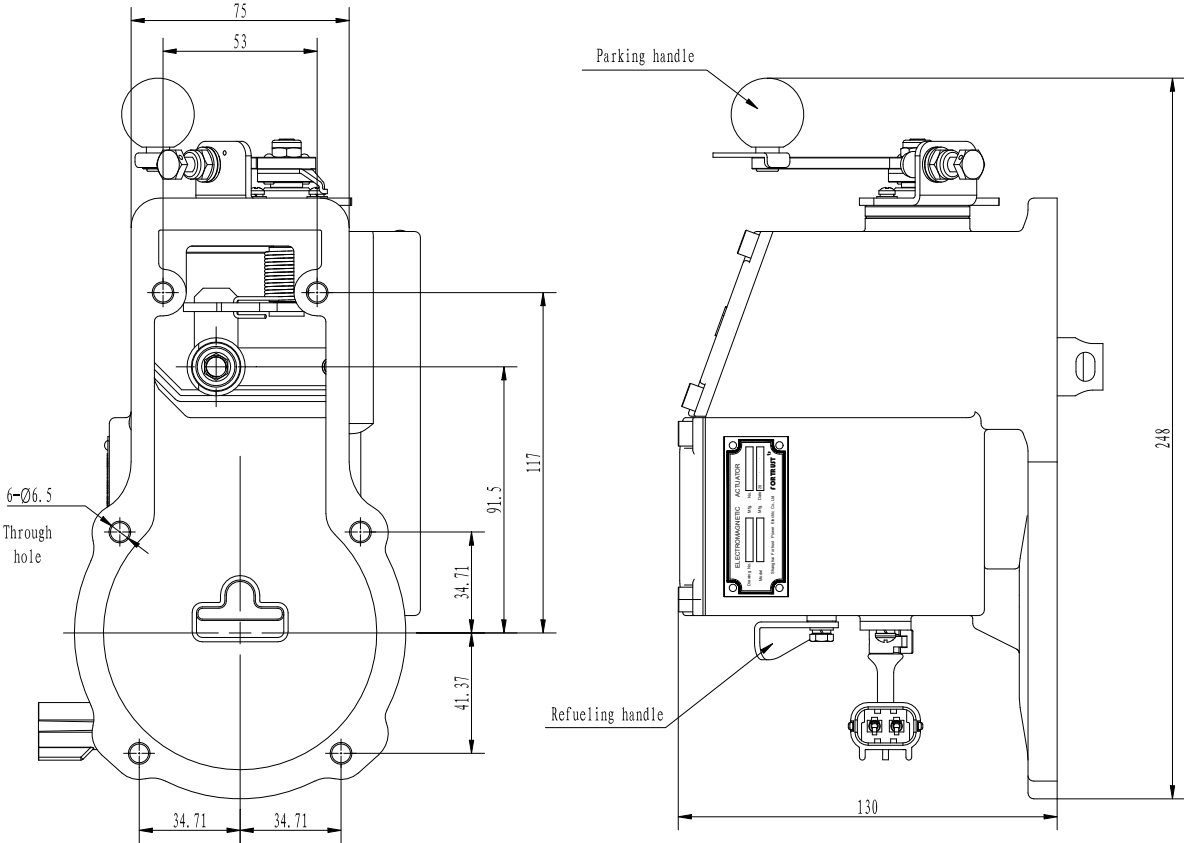

Figure 2.2.1. The outline and installing size of the A800C-W electromagnetic actuator

2.2.2 A900C-W electromagnetic actuator

- WORKING VOLTAGE: DC24V
- WORKING TORQUE: 0.9N.m
- WORKING STROKE: 22.5 mm

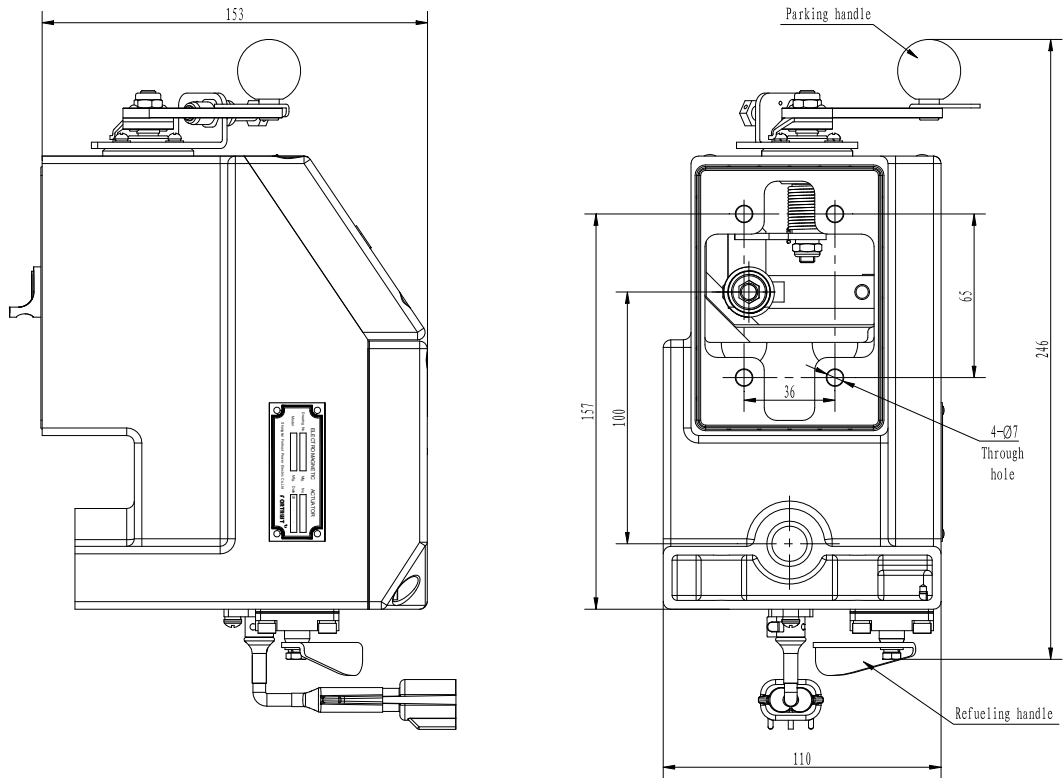

Figure 2.2.2 The outline and installing size of the A900C-W electromagnetic actuator

2.2.3 A1000C-W-d1 electromagnetic actuator

- WORKING VOLTAGE: DC24V、DC12V optional (order specify)
- WORKING TORQUE: 1 N.m
- WORKING STROKE: 22 mm

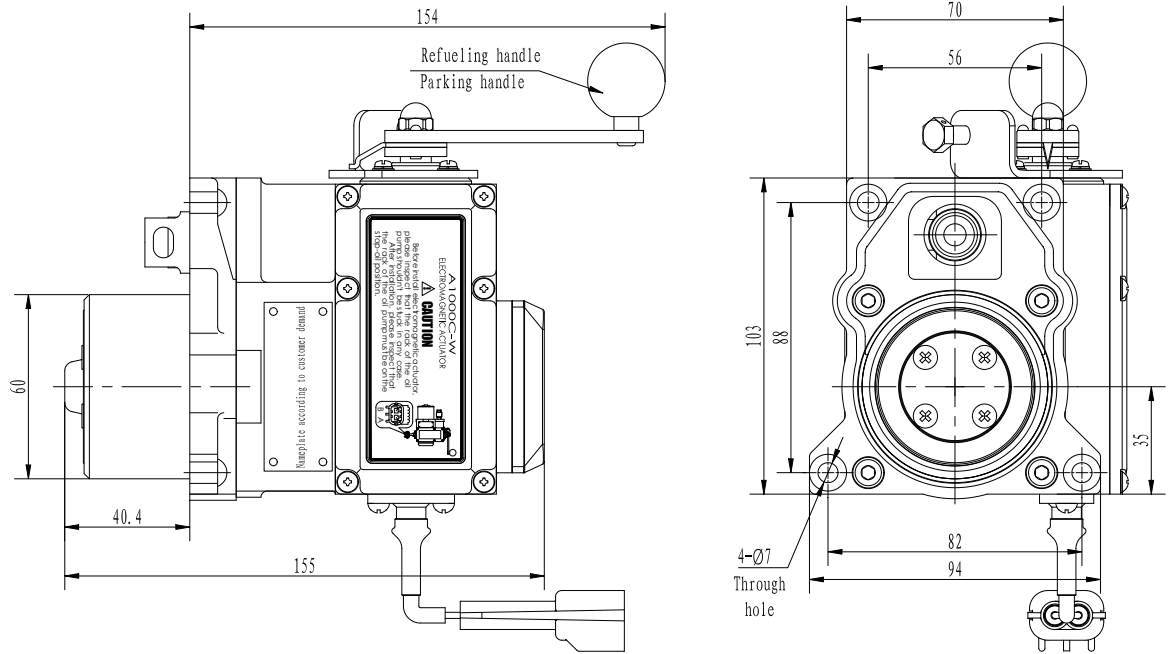

Figure 2.2.3 The outline and installing size of the A1000C-W-d1 electromagnetic actuator

2.2.4 A2000C-W-d1 electromagnetic actuator

- WORKING VOLTAGE: DC24V
- WORKING TORQUE: 2 N.m
- WORKING STROKE: 22mm

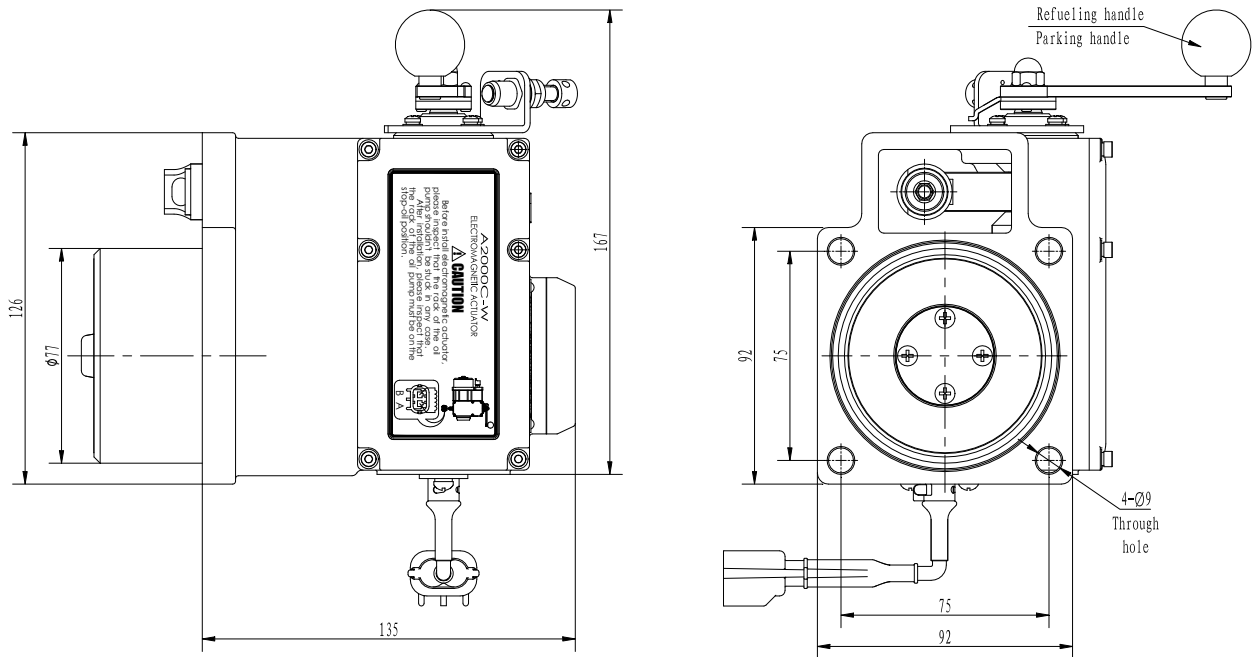

Figure 2.2.4 The outline and installing size of the A2000C-W-d1 electromagnetic actuator

2.2.5 A07A-W electronic characteristics

- WORKING VOLTAGE: DC12V (Suitable for 9~16V) / 24V (Suitable for 16~32V)
- WORKING TORQUE: 0.8 Nm
- WORKING STROKE: 15mm

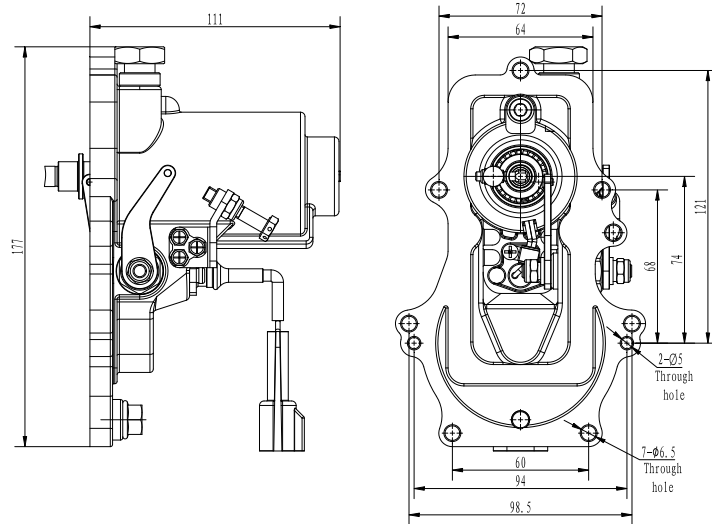

Figure 2.2.5.1 The outline and installing size of the A07A-WL-BQ (left and right can choose, This chart is right) electromagnetic actuator

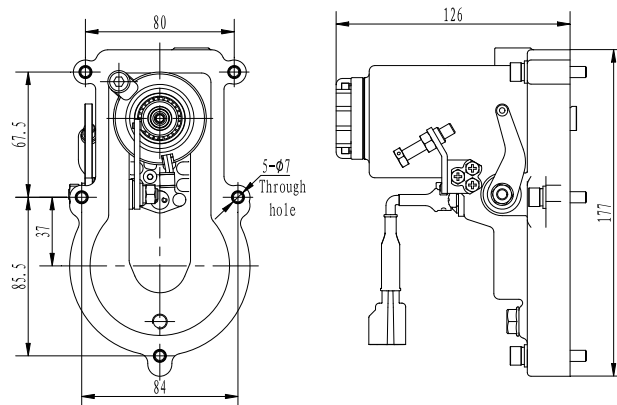

Figure 2.2.5.2 The outline and installing size of the A07A-W-LL(LR)-PL (left and right can choose, This chart is left) electromagnetic actuator

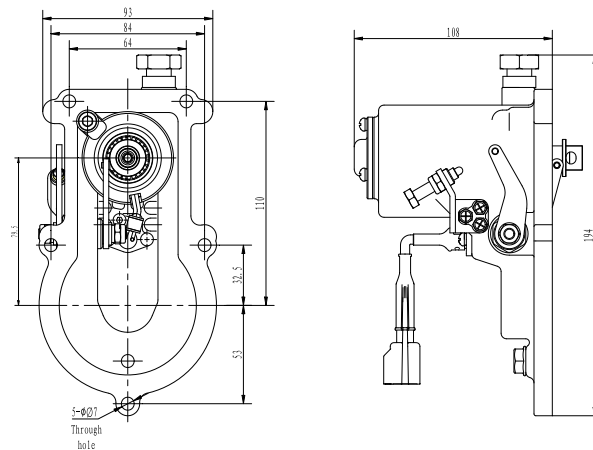

Figure 2.2.5.3 The outline and installing size of the A07A-W-LL(LR)-PM (left and right can choose, This chart is left) electromagnetic actuator

2. 2. 6 A08A-W electromagnetic actuator

☑WORKING VOLTAGE: DC24V、DC12V optional (order specify)

☑WORKING TORQUE: 0.8N.m

☑WORKING STROKE: 18mm

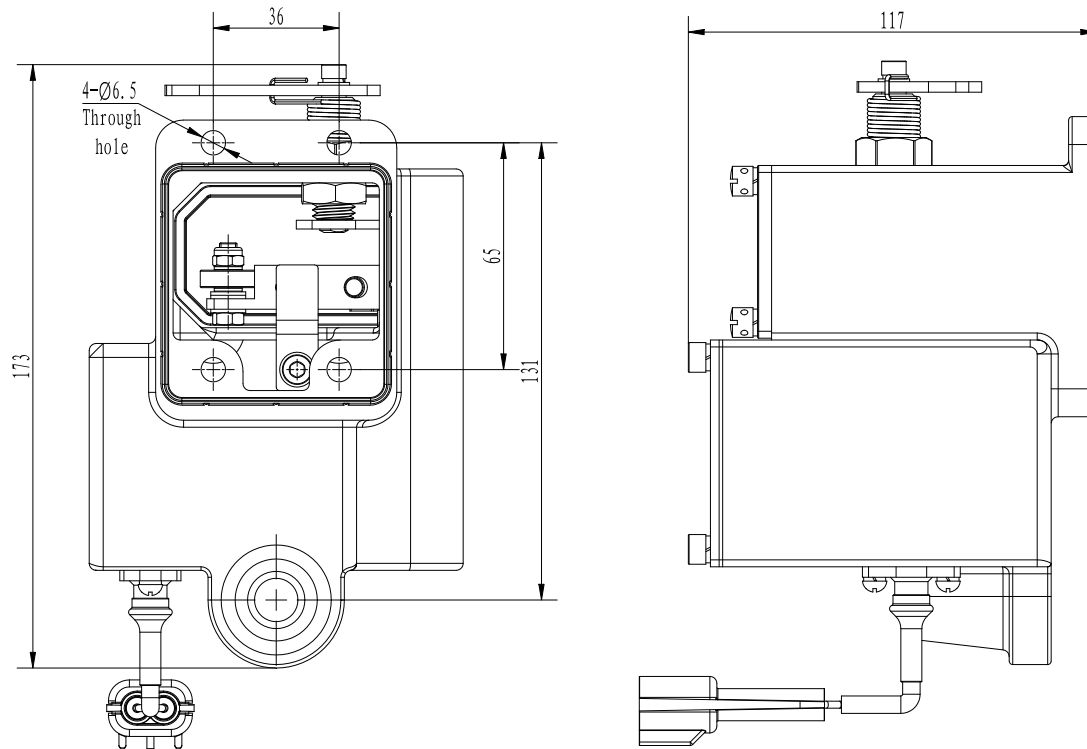

Figure 2.2.6 The outline and installing size of the A08A-W electromagnetic actuator

2. 2. 7 A3A-W electromagnetic actuator

☑WORKING VOLTAGE: DC24V、DC12V optional (order specify)

☑WORKING TORQUE: 0.9Nm

☑WORKING STROKE: 19mm

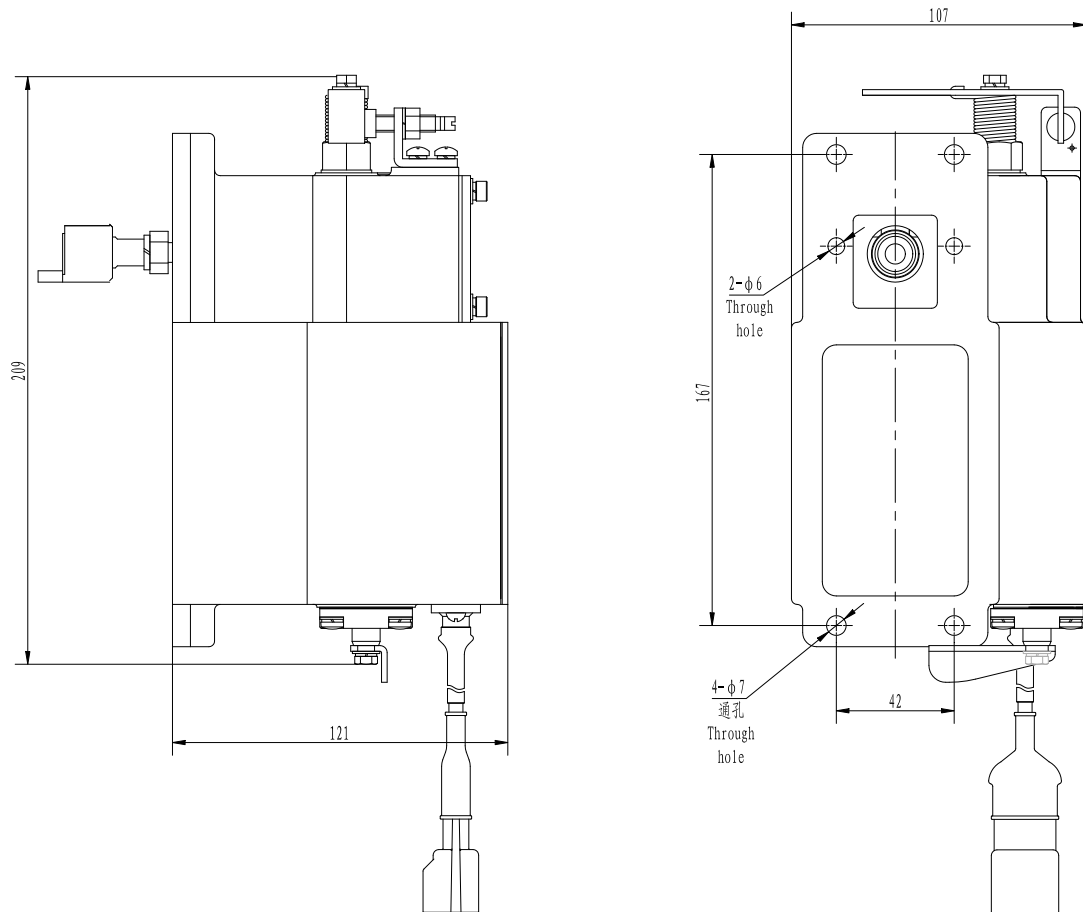

Figure 2.2.7 The outline and installing size of the A3A-W electromagnetic actuator

2. 2. 8 CA2-W electromagnetic actuator

☑WORKING VOLTAGE: DC24V

☑WORKING TORQUE: 1.2N.m

☑WORKING STROKE: 20mm

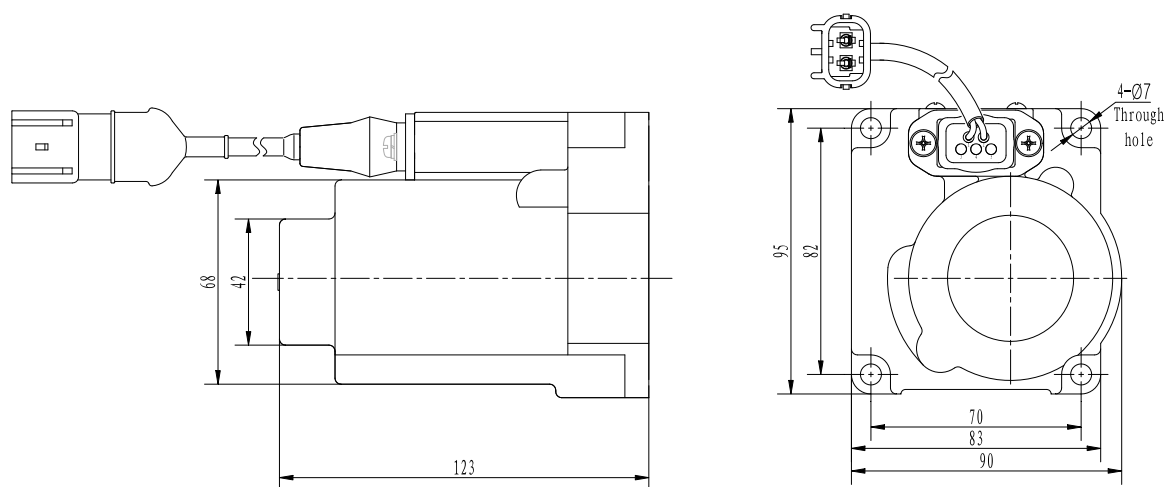

Figure 2.2.8 The outline and installing size of the CA2-W electromagnetic actuator

2. 2. 9 A1AWL electromagnetic actuator

☑WORKING VOLTAGE: DC24V、DC12V optional (order specify)

☑WORKING TORQUE: 1N.m

☑WORKING STROKE: 21mm

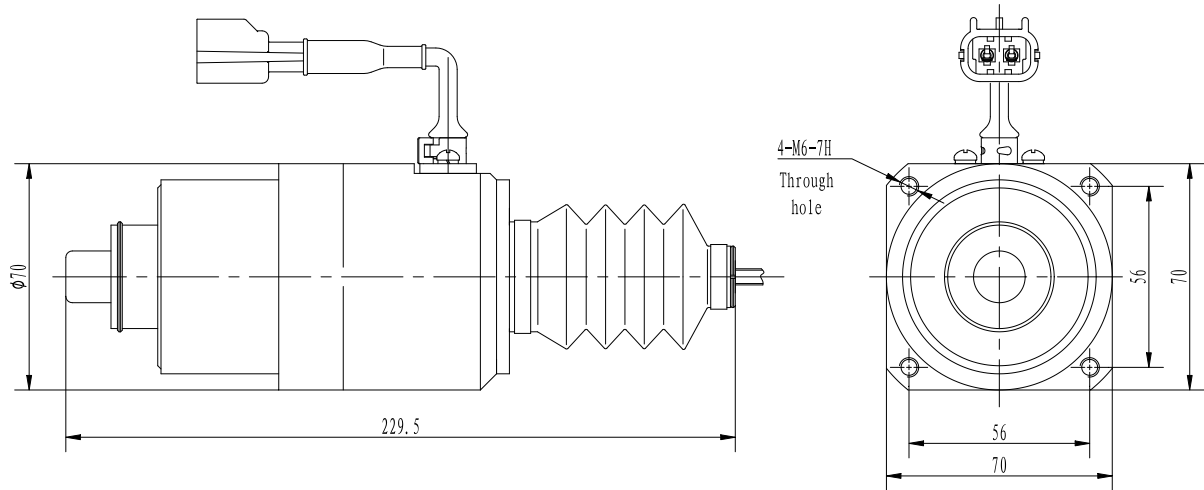

Figure 2.2.9 The outline and installing size of the A1AWL electromagnetic actuator

2. 2. 10 A1AWT electromagnetic actuator

☑WORKING VOLTAGE: DC24V、DC12V optional (order specify)

☑WORKING TORQUE: 1N.m

☑WORKING STROKE: 21mm

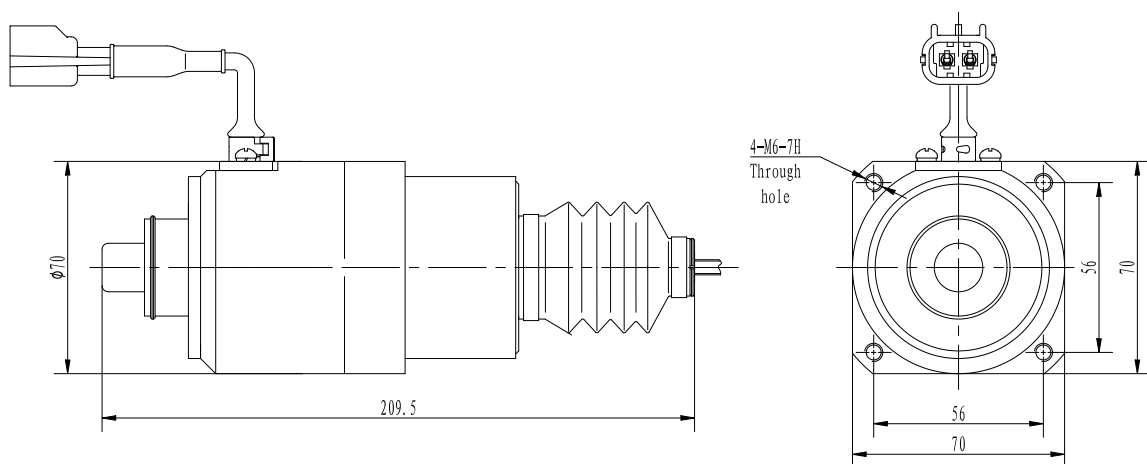

Figure 2.2.10 The outline and installing size of the A1AWT electromagnetic actuator

2. 2. 11 A3B electromagnetic actuator

☑WORKING VOLTAGE: DC24V、DC12V optional (order specify)

☑WORKING TORQUE: 0.9N.m

☑WORKING STROKE: 25°

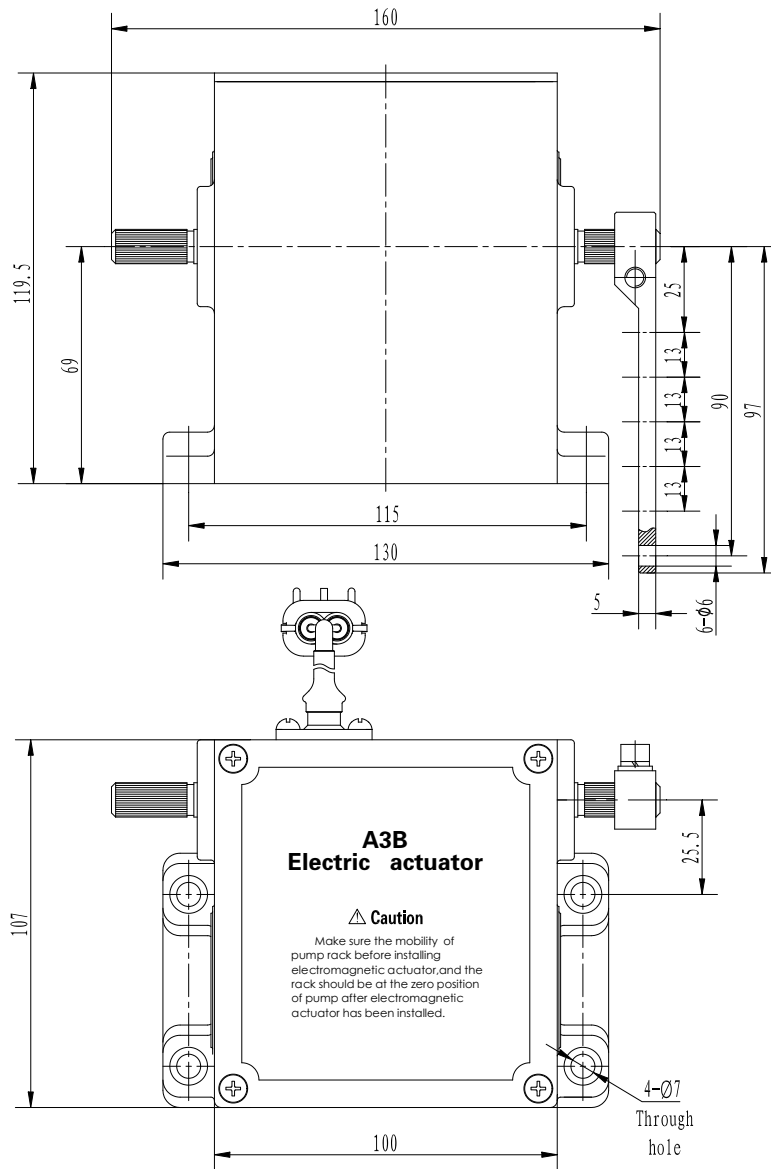

Figure 2.2.11 The outline and installing size of the A3B electromagnetic actuator

2.3 Speed Pick-up

The speed sensor of this electronic governor system we used is the passive magnetoelectric speed sensor, it output the speed signal through the magnet gap change that caused by the rotation of the speed measuring gear, and the change will generate the induced electromotive force in the coil of the speed sensor. The speed sensor should be fixed on the engine gear plate when install it, the engine speed will be got through the reaction of flywheel gear numbers; The best gap of installation of the speed sensor is return $1/2 - 3/4$ circle(about 0.45mm) after touching the gear teeth. $f=nz/60$, f is frequency (Hz) , n is speed (speed/minute),z is flywheel gear numbers. Customer could use this formula to calculate and get the initial speed value of speed controller, and adjust the value to the required value after starting the engine.

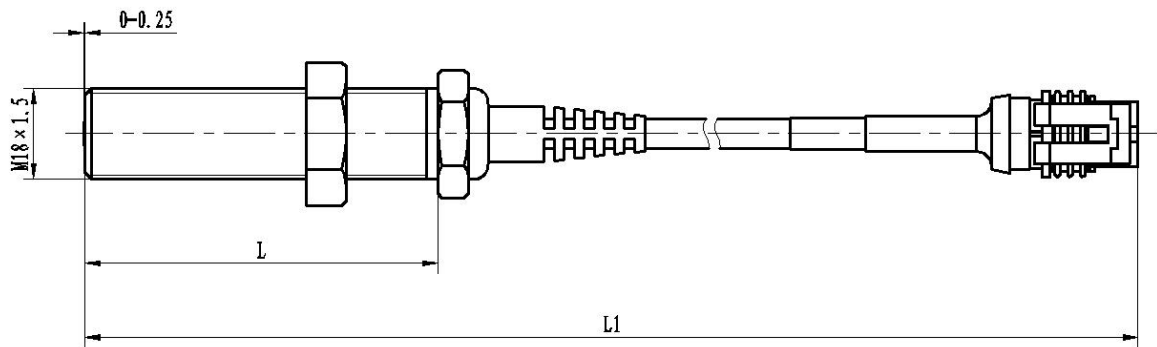

Figure 2.3 The outline and installing size of series speed pick-up (M16、 M18、 inch series can choose This chart is M18)

★Speed sensor produced by Fortrust have different model with different installing dimension, people choose according to your demand.

Cautions: the use of speed sensor to the electronic control system shall not be shared with other system, otherwise it may cause very serious consequences!

3 Installing and Debugging

3.1 Installing Of The Electronic Governor

The C2005 speed controller is usually installed in a control cabinet or fixed on other external device of the engine, and please choose the place with dry air and appropriate temperature. The the speed controller should be far away from the water, the mist or the freezing object, even if it has the dampproof surface; the speed controller also should be far away from the high temperature and the thermal radiation to avoid it was damaged. If the place is near the water or with the heavy moisture, please install the controller by vertical direction.

Cautions:

1. The engine should have its own over speed protection device, it cannot only rely on the control system of electronic governor to stop over speed.
2. Must match with the trimmer potentiometer between terminal 7 and terminal 9 external ports; If trimming potentiometer is damaged, it must be a terminal 7 and terminal 9 conductors are used for short circuit, shall not be suspended between two terminals use.

3.2 Connection Diagram Of The ESG2005 Series Electronic Governor System

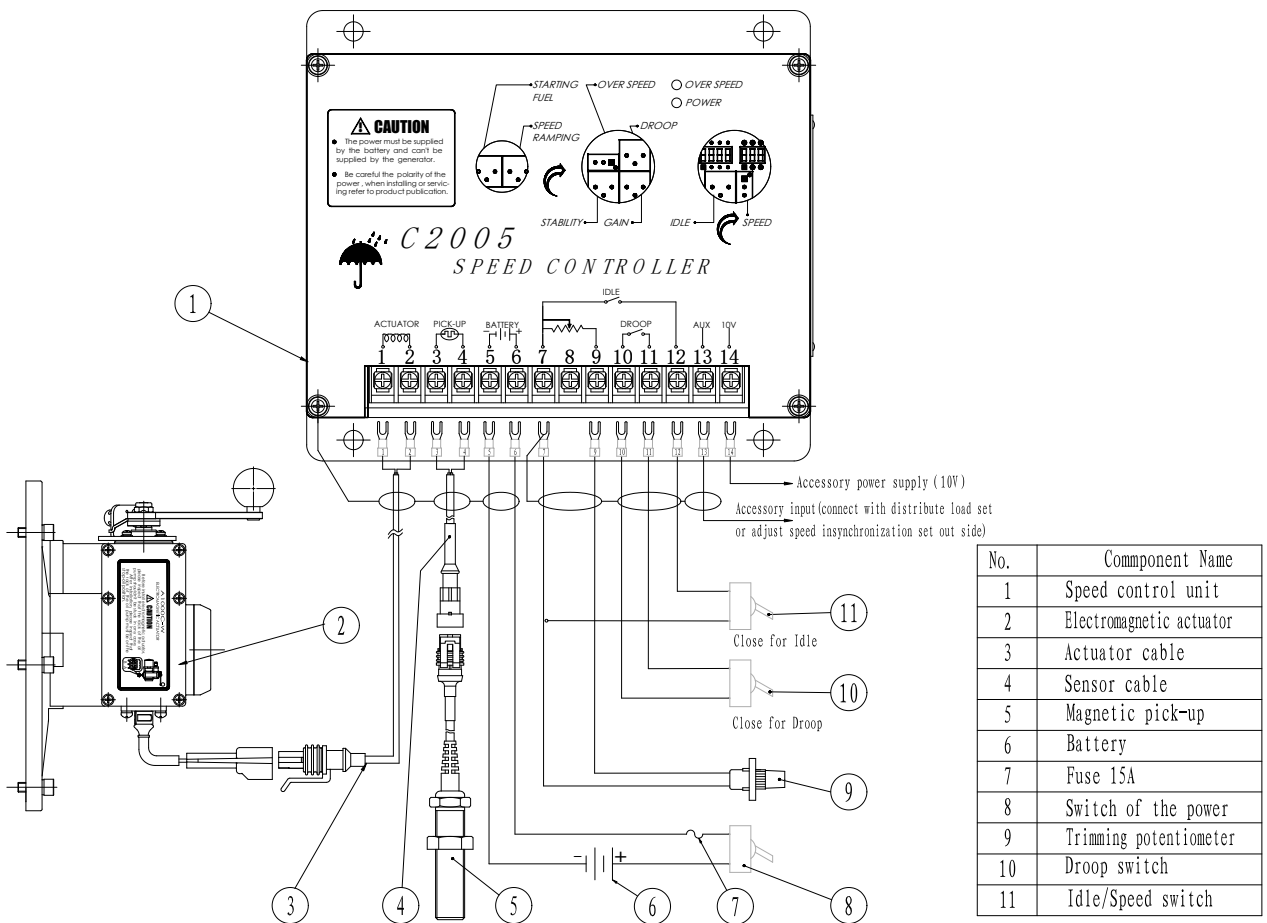

Figure 3.2 Connection diagram of the ESG2005 series electronic governor system

3.3 Debugging before starting engine

If start the engine in the first time, please strictly check as below:

▲ Check the flexibility of the oil rod

The whole oil supply of the pump should work without jamming and the oil rod works flexibly. If the oil rod worked inflexibly, it means the control system is not work properly and it may cause the major failure of the engine such as speed unsteady, over speed and run away.

▲ Check the flexibility of the actuator

There should have no gap between the shaft of the actuator and oil rod, the actuator is working flexibly, the minimum section is reach to stop oil and the maximum section is reach to supply oil at larges;

▲ Check the relative electrical connection

According to figure 3.1 wiring diagram or the requirement of mating electronic governor system, please check if the electrical connection is correct and battery voltage is accord with the requirement (No-load is slightly larger than 24V (12V) ,starting moment is not less than 18V (9V));

▲ Check the factory parameter setting

The electronic governor produced by Fortrust have been finished the parameter setting usually according to customer's supply agreement, so you just need to check it, if you cannot get the information under the special situation, please check and set as below:

(1) Check the position of starting Fuel if it is on larger position (Clockwise is for increasing); Check the potentiometer section of GAIN and STABILITY, please set them to 12'clock position if you cannot be sure;

(2) Dial switch position unless specifically stated, please set according to the following requirements: compensation capacitance adjustment four digit dial switch SW2 is arranged in the 1 on 2 on 3 under 4 under state (with setting the reference compensating capacitor adjustment table), to adjust the state of three bit code dialing switch SW1 is arranged in the 1 on 2 under 3 under the state (with set reference state switch adjustment);;

(3) Turn the high speed / low speed switch to low speed, the SPEED RAMPLING potentiometer at the end of the slower acceleration slope, and in the uncertain case, please set it at 12 o'clock position(the clockwise direction is the end of slower acceleration slope);

(4) The speed of controller have been preset according to user data, you don't need to adjust the the speed setting potentiometer of the controller before starting the diesel engine, you just need to adjust it accurately after starting the engine. If you cannot sure the speed setting value, please turn the rated speed setting potentiometer by

anticlockwise several circles, meanwhile observe the position of the idle potentiometer, then set it to 12'clock position.

3.4 Parameter adjustment of speed controller after starting engine

Cautions: Before setting the parameter, please pay more attention to the following.

Except the rated speed potentiometer (can turn 25 circles, see figure 3.2), other potentiometer of the controller such as Stability, Gain, Idle cannot be turn more than one circle, their largest adjustable angle is 270° , it is about from 7'clock to 4'clock by clock direction. When you are setting the parameter, please don't turn it over this range, otherwise the potentiometer will be damaged and result in the major failure such as the engine stop, instability and over speed. All of the above potentiometers are the precision electron device, please adjust slowly by the special tools to avoid the man-made sabotage.

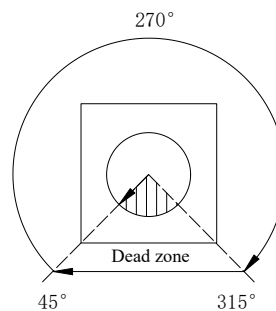

Figure 3.2 The adjusting position of the potentiometer

3.4.1 Adjustment of the starting fuel (smoke)

You can adjust the fuel supply of the actuator by rotating the STARTING FUEL potentiometer, which can ensure the engine start smoothly with certain starting fuel, and meanwhile, it can reduce the black smoke caused by the excess fuel supply and incomplete combustion; After starting the engine, the speed switching switch to idle position, adjust the idle speed potentiometer (IDLE), make the engine running at idle conditions required, and then counter clockwise rotation starting oil volume potentiometer, until the engine speed begins to drop, then the callback to idle speed stability to stop, and stop restart. If the engine start-up difficulties, can be properly increased based on this starting oil quantity (clockwise rotation is the starting oil amount increasing direction).

The starting fuel quantity of the engine is influenced by the temperature condition, in order to make the engine start smoothly under any conditions, you shall set the STARTING FUEL potentiometer in the larger position without black smoke.

3.4.2 High/Low Speed Adjustment

The controller should control on the idle position after starting the engine, the idle potentiometer is used for

setting speed value under the idling condition, turn clockwise is for increasing speed, turn anticlockwise is for decreasing speed; turn the idle potentiometer slowly until to the required value according to the speed value under the condition of starting up.

When turn the switch to OFF terminal, the engine will increase speed from idle value to rated speed gradually according to the raising speed slope. The speed potentiometer is used for adjusting the rated speed of the engine, turn clockwise is for increasing speed and turn anticlockwise is for decreasing speed until to the required value.

Need to pay attention to is, when adjust the rated speed potentiometer or external Trimming Potentiometer to adjust the rated engine speed value. At the same time, will affect the idle speed setting value, so after setting the rated speed value, it should be on the idle value correction.

3. 4. 3 Adjusting the ACC time

The time when the engine turns from idle status to the rated speed status is called ACC time. You can adjust the SPEED RAMPING potentiometer to adjust the ACC time.

The clockwise adjustment is the extended direction of the ACC time, on the other hand, it is the shorten direction of the ACC time. Under the working condition, you can make adjustment within the scope of 266Hz/S to 1300Hz/S, and it also can be customized according to the special requirements.

3. 4. 4 Overspeed protection setting

The speed controller in the factory and overspeed protection value has according to users with the engine models had set, users are advised not to adjust. If the user must be adjusted is necessary by the experience of operating personnel in accordance with the following steps to set (for dual band switch, the controller should be at top speed and the actual use of the value set for a reference point):

- I 、 Clockwise rotation overspeed setting potentiometer (OVER SPEED) 3 to 5 ring;
- II 、 Start the engine, the engine running at maximum rated speed (1500 rpm);
- III、 Slowly clockwise adjustment corresponding to the rated speed potentiometer, the engine speed increases gradually, overspeed protection until the required limit values (such as setting the overspeed limit value is 120% of the rated speed, the corresponding limit is 1800 rpm);
- IV 、 Slowly adjust potentiometer counterclockwise until the red overspeed setting, indicating LED lamp (OVER SPEED) lit up, at the same time the engine realizes the overspeed protection shutdown;
- V 、 Power off a few seconds (if the speed controller with self starting control system should also press the stop button, in case of a system without the case of preparedness suddenly the motor starting), and the rated speed

potentiometer counterclockwise rotation of 1 laps later, re energized, this time overspeed light should be destroyed, and then start the engine;

VI、 Adjust the rated speed potentiometer or with the adjustment speed trimmer potentiometer, make the engine run at the rated speed of the desired value. Thus, overspeed protection settings completed.

The need for overspeed protection setting value is verified, the user can through the clockwise rotation of the rated speed potentiometer to increase the rated engine speed gradually, until the engine produces overspeed protection shutdown, and record the speed value, namely for overspeed protection setting value. After verification, and then press the above step five or six order adjustment can be. If you don't use up to 2 of the rated speed value, and only a rated speed value, suggest to 1 rated speed as the working point set, and the frequency setting switch remove.

Cautions: 1、 Non professional operation personnel shall not operate;
2、 Overspeed protection limit setting values should not be set too low, so as not to load the flameout phenomenon unload time;
3、 If no special requirements, please do not to overspeed protection limit setting potentiometer(OVER SPEED) to adjust, in order to avoid the engine can not start, the engine speed is not up to the requirements, can not achieve the overspeed protection phenomenon.

3.4.5 Stability Adjustment

If the engine is starting with instable speed, you can adjust it as the below information. The stability adjustment has three steps and there are idle, high speed and full loading.

Cautions: The engine works under the stability of the idle, high speed and full loading is syntrophic, so adjust the system refer to three steps to the best stability. After reaching to the stability, adjust Gain potentiometer to the larger value to be sure the engine get the best dynamic indicator.

The engine instability has the periodicity and the aperiodicity.

Periodicity instability has the speediness and the low speed. The speediness is usually means the frequency is 3HZ or more, but the frequency is less than 3HZ is low speed instability. Low speed may cause the strong instability and pay more attention to that; If happened, please adjust the parameter to the speediness firstly, then adjust slowly to avoid to damage the machine or the accident happen.。

The stability adjustment of engine finished mainly through the adjustment of GAIN, STABILITY potentiometer and SWI switch. Gain Potentiometer is used for adjusting the sensitivity of the governor system, turn clockwise is for increasing, on the contrary is for decreasing. The stability potentiometer is used for adjusting the respond time of the governor system, turn clockwise is for increasing, on the contrary is for decreasing. The adjustment between Gain and Stability will let the engine works under the best condition.

When start the engine with instable status, please adjust as following:

Solution I :

1. Adjust Gain potentiometer: Turn clockwise Gain potentiometer, if instability is tend to increase, please turn anticlockwise until to stable; If the stable point cannot be found, please turn Gain to relative stable position; then turn anticlockwise to a little back to be sure the stability;

2. Stability Potentiometer: Turn clockwise the Stability potentiometer, if the instability is tend to increase, please turn anticlockwise until to stable; If the stable point cannot be found, please turn Stability to relative stable position; then turn anticlockwise to a little back to be sure the stability.

Repeat 2 steps of the solution, usually the engine will reach to the stability, if failed, please see the below solution.

Solution II : Adjust SW1:

We know from the above, the dial switch of the controller SW1 is the status switch, it is used for changing the controller signal way to adapt the different engine, for the meaning of each dial please see the below:

Chart 1. SW1 State regulation (said table in the upper and lower correspond to the ON and OFF)

Project	Dial switch state	Application
SW1(Three)	1 on 2 on 3 Under	Suitable for large damping force model,for large and medium-sized diesel or gas engine can use this state.
SW1(Three)	1 Under 2 on 3 Under	Small diesel for the following 100KW machine, a dynamic index and stability index better.
SW1(Three)	1 Under 2 Under 3 on	Between the engine and the generator is suitable for soft connection unit, miniature models of 30KW following dynamic index and stability index better.

To be attention, all of the above solution we got from the plenty of matching test and daily service experience, for the problem caused by the engine design, manufacturing or system integration may not be classified as the above, even the phenomenon of state cross, that is why we see the above classify is not specific correspondence.

No.1 positon of SW1 is designed for the respond time of the controller to governor;

No.3 positon of SW1 is based on the elimination of a soft friction reflected in by the engine driven

generators connected state when rapid drift caused by the speed control system design;

From the above analysis, when the engine rapid instability, and the engine speed is higher the unstable frequency is higher, and vice versa, then, may try to be SW1 1 dial the switch in the OFF end (below), to reduce the sensitivity of the speed controller of high frequency signal; also try to SW1 3 dial the switch in the ON end (above), in order to eliminate the possible connection soft friction caused by rapid unstable state; adjust the good state, then the method of repeated scheme is adjusted, if still not stable, according to chart 2 corresponding SW2 terminal switch state, and press chart 2 to adjust, dial switch after setting methods shall be repeated again scheme is adjusted, until the engine stability

Chart 2. SW2 Capacitive compensation adjustment

If fast is not stable, please according to the state of SW2 to find the corresponding position in the chart, and downwards along the chart			
If it is slow and unstable, please according to the state of SW2 to find the corresponding position in the chart, and adjusted upwards along the chart			
4	3	2	1
ON	ON	ON	ON
ON	ON	ON	OFF
ON	ON	OFF	ON
ON	ON	OFF	OFF
ON	OFF	ON	ON
ON	OFF	ON	OFF
ON	OFF	OFF	ON
ON	OFF	OFF	OFF
OFF	ON	ON	ON
OFF	ON	ON	OFF
OFF	ON	OFF	ON
OFF	ON	OFF	OFF
OFF	OFF	ON	ON
OFF	OFF	ON	OFF
OFF	OFF	OFF	ON
OFF	OFF	OFF	OFF

When there is slow and unstable, can try SW1 1 dial the switch in the ON end (above), or according to

the chart 2 To adjust, each tuned a should be repeated scheme method to adjust, until it reaches the stable;

When the non periodic instability, can also be according to the chart 1 and chart 2 ways to adjust; if the above scheme is still not resolved successfully, may be the engine itself, should check the fuel system, intake system, load stability, and evaluate the performance of the engine, also should check the power supply stability,

whether the rotational speed signal amplitude meet the requirements (idle speed is greater than 1.5Vpp, the normal speed of more than 4Vpp), shielding effect of speed signal line and the external control signal line is good etc.

3. 5 Adjusting the DROOP

3.5.1 The adjustment of the DROOP potentiometer is used in many sets of the parallel operation;

3.5.2 First of all, the terminal every single of 10, 11 short circuit, open the speed droop function controller, drooping characteristic of engine become soft (when 10, 11 terminal short circuit, the speed of the engine will have small changes, electromagnetic variation amplitude depends on the size of your choice of actuator), So that the engine speed decreases with the increase of engine load, when the engine at full load, the engine speed to reduce the value and the nominal speed ratio, called the steady state speed rate,, this value can be used by adjusting the rate of the potentiometer to change the steady state speed regulation, clockwise regulation to increase the steady state speed rate direction, whereas decreases, the user should be adjusted according to the related standard or need; When you adjust the DROOP potentiometer, the speed of the engine will have a tiny change and you shall revise the speed of the engine.

3.5.3 The following example will explain the process of adjusting the steady-state adjustable rate:

For example, a engine of 1500RMP needs 3% steady-state adjustable rate, this is to say, when in the no-load status, it is 1545 RMP; when in the full-load status, it is 1500 RMP.

a. Please confirm the speed controller of all external attachments have been connected properly before regulating, terminals 10, 11 have been shorted;

b. After the engine starts , in the no-load status, you shall adjust the DROOP potentiometer to about the 12 o'clock direction, then adjust the SPEED potentiometer or the FREQ TRIM potentiometer, adjust the speed of the engine to 1545 RMP;

c. After the adjustment, slowly increase load to full-load status, at this time, the speed of the engine will slowly decrease with the load adding;

d. Record the speed value in the full-load status. When the speed value >1500RMP in the full –load status, the steady-state adjustable rate is smaller, and you shall adjust the SPEED potentiometer in the clockwise direction;

on the other hand, the steady-state adjustable rate is larger, and you shall adjust the SPEED potentiometer in the counterclockwise direction;

e. Note: you can't adjust the SPEED potentiometer or the FREQ TRIM potentiometer in the full-load status! After the step d, unload the engine to no-load.;

f. In no-load status, the rotate speed won't be 1545 RMP as set before. You shall continue to adjust the SPEED potentiometer or the FREQ TRIM potentiometer to make the speed to be 1545RMP (You can't adjust the DROOP potentiometer during this period.);

g. Continuously repeat step c to step f until the speed of the engine achieve 1545 RMP in the no-load status and 1500 RMP in the full-load status. That is to say you finish the adjustment of the required 3% steady-state adjustable rate.

3.6 Auxiliary input

3.6.1 Terminal 13,as the auxiliary input signal introduced from the load allocation unit, automatic synchronization device and other control system which contains ramp generator, is used for automatic synchronization and automatic load distribution。 If the synchronizer is used alone, and is not connected with the load balancer,should the resistance between 13 and 14 terminals connected to a $3M\Omega$ To match the voltage。

3.6.2 When introducing the auxiliary input signal, the speed of the engine will change slightly, you shall revise the speed of the engine by adjusting the SPEED potentiometer or the FREQ TRIM potentiometer again。

4 System Troubleshooting

4.1 Fault judgment of the electronic governor

The fault of the electronic governor will cause the engine performance degradation which may lead the engine shut down. If you can judge this is the fault of the electronic governor, you just shall change the electronic governor; if there are something trouble with the engine and the auxiliary system which incarnate the engine speed less than the using requirement, and then the problem can't solve even you replace the electronic governor. Thus you shall analyze the problem comprehensively and validate to determine it.

Symptom	Test	Probable Fault
Engine can not start	Battery	Voltage between Terminals 5 and 6 Should be 12V DC or 24V DC, And pay attention to electronic governor power (POWER) light is on.
	Speed Controller	Overspeed limit value is set too low, causing the overspeed protection (This situation OVER SPEED indicating lamp will be bright).
	Pick-up	1、 The setting of the speed pick up is not correct and the space is too big.
		2、 Speed sensor cable bolt, Measuring the DC resistance should be 830-970Ω.
Actuator	1、 Actuator or linkage binding.	
	2、 Actuator cable bolt, measuring actuator coil resistance, resistance between 4 ~ 5 ohms.	
Actuator does not energize fully	Battery	Starting when measuring the battery voltage, if less than 14V battery undervoltage, need to recharge.
	Actuator	Actuator or linkage binding.
Unsteady engine speed	Speed Control Unit	1、 Adjust the stability and the gain of the control unit according to 3.4.5.
		2、 Voltage between Terminals 14 and 7 Should be 10±0.5V.
Engine Overspeed	Speed Control Unit	1、 The number of engine gear is wrong and the rate speed is high
		2、 The gain is set too low and sensitive degree is not enough, which bring about too high instant speed
		3、 speed limit value is set too high.
		4、 Defective speed control unit.

	Actuator	1、 Actuator or linkage binding.
		2、 if zero position of the actuator is not according to actuator of the oil pump, actuator cannot cut up the oil to the oil pump after losing power
	Pick-up	If error speed sensor signal happens, please Check wiring.

4.2 Insufficient Magnetic Speed Sensor Signal

When the speed sensor signal is stronger, it can resist the external pulses , the speed sensor can measure the outputted signal which is more than 3volts .When the voltage is less than 3volts, you shall reduce the tooth gap between the speed actuator and engine ,which can improve the amplitude of the signal. The gap shall less than 0.45mm. If the voltage is still less than 3 volts, you shall check the whether the magnetism of the speed actuator is too weak. .

4.3 Electromagnetic interference (EMI)

The electronic governor system can be adversely affected by large interfering signals that are introduced through the cabling or through direct radiation into the control circuits. To avoid the medium interference, all the speed controller produced by Our company include the filter unit and shielding designs that can protect the sensitive circuits from the external interference.

It is difficult to predict the value of the interference. You shall consider all the possible range of the interference such as the radio communications of the space field, wireless walkie-talkie, and wireless radio transmitter and also including the use of magneto, solid-state ignition systems, and voltage adjuster or battery chargers.

When you doubt that space field or other systems will affect the speed governor system operation by conduction or direct radiation during the using period, we suggest that you shall use the double shielded cables as the external cables of the controller. Also ensure that one terminal of the shielded cable which includes the 360 degree of the speed actuator shall connect to the shell of the controller. And mount the speed control unit on a grounded metal back plate or place it in a sealed metal box to avoid the electronic interference. There will be a good effect when using the metal cover or the metal container. The most common anti-interference measure is to use the shielding wire. If using the generator with brush, you can't ignore the electronic spark interference, so you shall use the

special shielding measure to the huge interference environment. If you can't solve this kind of problems, please contact with our engineers. They will give you some more suggestions.



**Address: Room 803, Building A, Senlan Meilun Building, 555 Lansong Road,
Pudong New District, Shanghai**

Tel: 19851351321

Postcode: 200137

**Factory Address: No.49 Mingzhu Road, Qidong Coastal Area,
Jiangsu Province, China.**

Tel:19851351386

Postcode: 226236

Web: www.fortrustpowerele.com

Email: info@fortrust.cn

